

Series **AL**



AL 500

Operating instructions

**Before transporting and using the machine,
please read the instructions thoroughly!**

Seriové číslo / Serien Nummer / Serial Number _____

Service and information

Your BOMAR dealer:

Direct BOMAR contact:

BOMAR spol. s r.o.
Těžební 1236/1
62700 Brno
Czech Republic, EU

telefon: +420 – 533 426 100
fax: +420 – 533 426 109
e-mail: info@bomar.cz
www: <http://www.bomar.cz>

We are available:

Mondays to Fridays

7⁰⁰ – 16⁰⁰

Version:

1.05 / Sep. 2011
rev. 1

BOMAR, spol. s r.o. © – Subject to modifications and amendments.

EC Declaration of Conformity

1) We

BOMAR, spol. s r.o.
Těžební 1236/1
627 00 Brno, The Czech Republic
 Id.no: 48908827

declare herewith,

that the following designated device based on its conception and construction as well as the design launched by us meets the relevant basic safety requirements of the decrees of the government. In the event of any device modification not approved by us this declaration shall lose its validity.

Name: **Circular Saw**

Type range: **AL 500 Semi-automat**

Serial number:

Manufacturer: **BOMAR, spol. s r.o., Těžební 1236/1, 627 00 Brno**

Product data:

Determination: for cross dividing and cutting of bars and profiles made of aluminum, plastics, copper and its alloys with angle cut from -60° (L60°) to +90°(R90°)

Description:

stand, table, cutting unit with the saw blade and drive, microniser , Pneumatic-hydraulic unit, Microniser, el. switch board with control panel., safety covers, safety elements

Technical data: blade speed 50.m.s⁻¹, cutting angle -60°+90°

Total dimensions in mm (l x w x h) 1100 x 2350 x 1560,
 Supply voltage 3x400V, total power requirement 5,1 kW, weight 500 kg

The applied decrees of governments: **No. 17/2003 Coll.** (Directive 73/23/EEC)
No. 616/2006 Coll. (Directive 2004/108/EC)
No. 17/2003 Coll. (Directive 2006/95/EC)

The applied harmonized standards,

National standards and technical specifications: ČSN EN ISO 12 100-2:2004, ČSN EN 13 898 + A1:2009, ČSN EN ISO 13857:2008, ČSN EN 982 + A1:2008, ČSN EN 61000-6-2 ed.3:2006, ČSN EN 61000-6-4 ed.2:2007, ČSN EN 60204-1 ed.2:2007

The product is safe on condition of the common and determined usage.

The conformity judging was performed according to §12, par. 3, let. a), of the Law no. 22/1997 Coll. as amended

2) ²⁾ The declaration of conformity was carried out in the cooperation with the TÜV CZ s.r.o., Novodvorská 994, 142 21 Prague 4 – Czech Republic, Identification number: 63987121 - Inspection body no. 4002

The inspection certificate no . 02.099.898/10/07/02/0 was issued.

BOMAR, spol. s r.o.
 Těžební 1236/1, 627 00 Brno
 Czech Republic
 IČO: 48908827
 DIČ: CZ48908827

Brno, 2. 11. 2010 Alfred Pichlmann, Managing Director



Point of issue, datum

Name and function
 of the responsible subject

Signature

1) Name, address and identification number of the subject issuing the conformity declaration (producer of importer)

2) The authorized or accredited body co-operating on the conformity judging



If the equipment is installed without safety equipment offered by BOMAR, spol. s ro or its agents and used by the customer (or buyer) then EC declaration loses validity.
 EC Declaration of conformity is valid only if customer (buyer) installed the BOMAR safety equipment with the machine or with some other with equivalent safety device in accordance with current applicable regulations and standards.
 All machine elements and components that were built into the device by BOMAR, spol. s ro have been declared "identical" to a safety device, as offered by BOMAR, spol. s ro or its agents.

Content

1. SAFETY NOTES	7
1.1. Machine determination.....	9
1.2. Protective suit and personal safety.....	9
1.3. Safety notes for machine operator.....	10
1.4. Safety machine accessories.....	11
1.4.1. Total Stop.....	11
1.4.2. Workplace cover.....	11
1.4.3. Pedestal door.....	11
1.5. Umístění štítku stroje / Maschinenschild position / Position of machine label.....	12
1.6. Umístění bezpečnostních značek / Verteilung der Sicherheitszeichen / Position of safety symbols.....	13
2. MACHINE DOCUMENTATION	15
2.1. Technická data / Technische Daten / Technical data.....	17
2.2. Rezné rozsahy / Schnittbereiche / Cutting sizes.....	18
2.3. Rozměrové schéma / Aufstellzeichnung / Installation diagram.....	19
2.4. Popis / Beschreibung / Description.....	20
2.5. Transportation and stocking.....	21
2.5.1. Conditions for transportation and stocking.....	21
2.5.2. Transport and stocking preparations.....	21
2.5.3. Transport and stocking.....	21
2.5.4. Transportní schéma / Transport schema / Transport scheme.....	22
2.6. Activation.....	23
2.6.1. Machine working conditions.....	23
2.7. Band saw unpacking and assembling.....	23
2.7.1. Machine installing and levelling.....	23
2.7.2. Machine disposal after lifetime.....	23
2.7.3. Kotevní plan / Verankerungsplan / Grounding plan.....	24
2.8. Electrical connection.....	25
2.8.1. Check the running direction of the cutting wheel.....	25
2.9. Connecting to the compressed air supply.....	25
2.10. Filling of the cooling system.....	26
2.11. Check machine function.....	26
2.12. Saw blade.....	26
2.12.1. Saw blade size.....	26
2.12.2. Selection of the saw disk.....	26
3. MACHINE CONTROL.....	27
3.1. Starting the saw.....	29
3.2. Control panel.....	29
3.3. Machine control.....	29
3.3.1. Signal light.....	30
3.3.2. Cycle breaking.....	30
3.4. Circular saw adjusting.....	31
3.4.1. Set of clamping cylinders.....	31
3.4.2. Jaw console setting.....	31
3.4.3. Angular cut setting.....	32
3.4.4. Clamping adjusting.....	32
3.4.5. Speed adjusting of the arm lowering.....	34
3.5. Exhausting device (optional accessories).....	34
3.6. Material insertion.....	34
3.6.1. Handling agent selection.....	35
3.6.2. Insertion.....	35
4. MACHINE SERVICE	36
4.1. Saw disk dismantling.....	38
4.2. Saw disk installation.....	38
4.3. Cooling agents and chips disposal.....	39
4.3.1. Cooling liquid inspection.....	39
4.3.2. Chips disposal.....	39
4.4. Hydraulic, Greases and oils.....	39
4.4.1. Lubricant greases.....	39
4.4.2. Lubrication.....	40
4.4.3. Hydraulic oils.....	40
4.4.4. Hydraulic oil level check.....	41
4.5. Pressure system servicing.....	41
4.6. Machine cleaning.....	41
4.7. Worn pieces replacement.....	42
4.7.1. Belt replacement.....	42
5. SCHÉMATA / SCHEMAS / SCHEMATICS	44
5.1. Elektrické schéma / Elektroschema / Wiring diagrams.....	45
5.2. Pneumaticko-hydraulické schéma / Pneumatik-Hydraulikschema / Pneumatic-Hydraulic diagram.....	49

6. VÝKRESY SESTAV PRO OBJEDNÁNÍ NÁHRADNÍCH DÍLŮ / ZEICHNUNGEN FÜR BESTELLUNG DER ERSATZTEILE / DRAWING ASSEMBLIES FOR SPARE PARTS ORDER52

6.1. AL 500.....	53
6.2. Kusovník / Stückliste / Piece list – AL 500.....	54
6.3. Rameno / Sägerahmen / Saw arm - 1.....	55
6.4. Kusovník / Stückliste / Piece list – Rameno / Sägerahmen / Saw arm - 1.....	56
6.5. Rameno / Sägerahmen / Saw arm - 2.....	57
6.6. Kusovník / Stückliste / Piece list – Rameno / Sägerahmen / Saw arm- 2.....	58
6.7. Podstavec / Untersatz / Base.....	59
6.8. Kusovník / Stückliste / Piece list – Podstavec / Untersatz / Base.....	60
6.9. Kryt / Cover / Abdeckung.....	61
6.10. Kusovník / Stückliste / Piece list – Kryt / Cover / Abdeckung.....	62
6.11. Stůl / Table / Tisch.....	63
6.12. Kusovník / Stückliste / Piece list – Stůl / Table / Tisch.....	64
6.13. Válec zvedací / Hebezyylinder / Lifting cylinder.....	65
6.14. Kusovník / Stückliste / Piece list – Válec zvedací / Hebezyylinder / Lifting cylinder.....	66
6.15. Vana / Wanne / Tank.....	67
6.16. Kusovník / Stückliste / Piece list – Vana / Wanne / Tank.....	68
6.17. Rozvaděč / Verteiler / Distributor.....	69
6.18. Kusovník / Stückliste / Piece list – Rozvaděč / Verteiler / Distributor.....	70
6.19. Upínání horní / Spannvorrichtung oben / Top clamping.....	71
6.20. Kusovník / Stückliste / Piece list – Upínání horní / Spannvorrichtung oben / Top clamping.....	72
6.21. Válec upínací / Spannzylinder / Fixing cylinder 1.....	73
6.22. Kusovník / Stückliste / Piece list – Válec upínací / Spannzylinder / Fixing cylinder 1.....	74
6.23. Válec upínací / Spannzylinder / Fixing cylinder 2.....	75
6.24. Kusovník / Stückliste / Piece list – Válec upínací / Spannzylinder / Fixing cylinder 2.....	76
6.25. Válec / Zylinder / Cylinder.....	77
6.26. Konzola / Konsole / Console.....	78
6.27. Klíč / Schlüssel / Key.....	79
6.28. Díl připojovací / Anschlussteil / Attachment part.....	80

1. **Safety notes**

The operating instructions must be read by the person, who keeps in touch with the machine before transportation, installation, using, servicing, repair, stocking or removal!

The operating instructions include relevant information. The operator must familiarise himself with the install and operation, safety notes and machine servicing, because reliability and service life must be reached. The operating instructions must avoid risks, which are linked to work on the machine. Before transporting and using of the machine, please read the instructions thoroughly!

Attention!

*The operating instructions must be available at the machine!
Keep the operating instructions in good condition!*

1.1. Machine determination

The band saw **AL 500** is determined for cross dividing and cutting of bars and profiles made of aluminum, plastics, copper and its alloys with angle cut from -60° (L60°) to +90°(R90°).

Combustible materials are excepted for cutting! Any other usage and operation outside this range are unauthorized and the manufacturer/supplier does not accept any responsibility for any damages resulting from such misuse. **The operator has full responsibility!**

The machine is equipped with safety and protective guarding for operator and machine protection. Nevertheless, this safety and protective guarding cannot prevent injury. Service personnel must read this chapter and comprehend it, before he starts to work on the machine. **Always keep instructions about work safety!** Service personnel must take into account other aspects of the risk, which refer to the ambient conditions and the material.

Attention!

Consider the safety signs on the machine. Do not remove or damage them!

1.2. Protective suit and personal safety

Wear tight fitting overalls! Loose fitting clothes may be caught with machine parts and cause serious injury.

Wear protective gloves! Material cuts and saw band have sharp edges and may cause serious injuries.

Attention!

*Gloves you can use only at working material replacement (saw band)! The machine and accessories must be inactive!
If the machine is running, you must not wear gloves! It is dangerous, because some parts of the machine can catch gloves!*

Wear protective shoes with non-skid soles! The unsuitable shoes may cause balance loss and following injury. Falling work pieces may cause serious injuries too.

Wear protective goggles! Chips and cooling liquid may damage your eyes.

Always wear ear protections! Most of the machines emit up to 80 dB and may damage your hearing.

Do not wear jewellery and always tie back long hair! Moving machine parts can catch jewellery or loose hair and may cause serious injuries.

Operate the machine only when you are fit enough to work. Illnesses or injuries diminish concentration. Avoid machine work, which may compromise the safety of you and your colleagues!

1.3. Safety notes for machine operator

Attention!

*Machine can be operated by person older than 18 years!
Machine can be operated only person physically and mentally fit for this activity*

Machine can be operated only by one person. Machine operator is responsible for presence of other persons by the machine.

Keep instructions and orders about work safety!

Read the operating instructions, before you start to work on the machine! Keep the operating instructions in good condition!

Close covers before the machine starting and check, if the covers are not damaged. Damaged covers must be repaired or changed. Do not start the machine, if the cover is removed! Check, if the electric cables are not damaged.

Attention!

Do not connect the machine to electricity if the covers are removed. Do not touch the electrical equipment.

- Do not hold the material for clamping to the vice and for cutting!
- Do not operate with the buttons and the switches on the control panel, when you have gloves!
- For machine starting take care, that there is nobody in the working area of the machine (it means in the working area of the vice, the saw band, the saw arm etc.).
- In no circumstances touch the rotating elements.
- Work on the machine only when the machine is in good condition!
- Check at least once in a shift, if the machine is not damaged. If the machine is damaged, you must bring the machine in order and you must inform your superior!
- Keep your working area clean! Ensure sufficient lighting in the working area.
- Take off the spilt water or the oil from the floor and dry it. Do not touch the cooling liquid with bare hands! Do not set the nozzle of the cooling liquid, when the machine is started on
- Do not remove the chips from the working area of the machine, when the machine is started on!
- Do not use the compressed air for the machine cleaning or for the chips removing!
- Use the protective instruments for chips removal!
- Safety notes for the servicing and repairs

WARNING!

*After switching off the machine, the blade will still rotate for at least one minute. **Opening the door in this time is not allowed and can cause serious injuries!***

*fatal consequences! Always keep notes about work safety!
Otherwise, there is possibility of heavy injury!*

Switch off the main switch and lock it, before you start service work! Otherwise, there is possibility of hazardous machine starting.

Only qualified person can do the servicing and repairs. For parts changing, use only parts, which are identical with the originals. Otherwise, there is possibility of health hazard. Use only recommended type of the hydraulic oils and oils and lubricants!

Do not remove or do not lock the limit switches or safety equipments! Any use of the saw, accessories or machine parts other than that intended by the BOMAR, spol. s r.o. company is not permitted. The guarantee on this product will be afterward lost and BOMAR, spol. s r.o. takes no responsibility for caused damages.

Attention!

Only a qualified professional can carry out the servicing and repairs of the electric equipment! Take special care during the work with electrical equipment. High voltage shock can have fatal consequences! Always keep notes about work safety! Otherwise, there is possibility of heavy injury!

1.4. Safety machine accessories

The machine is equipped with safety accessories. It protects the operator from injuries and the machine before damage. The safety accessories are blocking accessories, emergency switches and covers. Check once in a week the function of the safety accessories. If the safety accessories are functionless, you must stop work and repair or change the safety accessories.

Enhanced risk!

Do not come into or intervene in the cutting area. Otherwise, there is possibility of heavy injury.

1.4.1. Total Stop

TOTAL STOP button is used for emergency switching – off the machine in case defect or health hazard. By pressing **TOTAL STOP** button is interrupted the supply of the electrical power.

If any damages or fault appears, immediately press TOTAL STOP button! Release the pressing button is possible by twisting of the upper part of the button.

1.4.2. Workplace cover

The cover is locked during operation. **Do not dismount safety cover.**



The band saw is stated to the operation, when the covers is closed!

1.4.3. Pedestal door

WARNING!

*After switching off the machine, the blade will still rotate for at least one minute. **Opening the door in this time is not allowed and can cause serious injuries!***

Doors are secured with a lock. After cutting, machine is unlocked after about 50 sec.



The saw is stated to the operation, when the cover is closed!

**1.5. Umístění štítku stroje /
Maschinenschild position /
Position of machine label**



Machine label is located at the rear of saw pedestal.

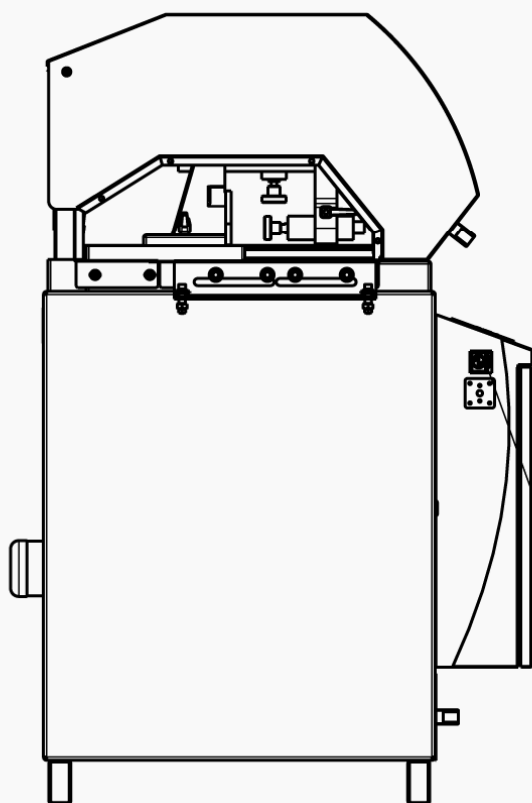
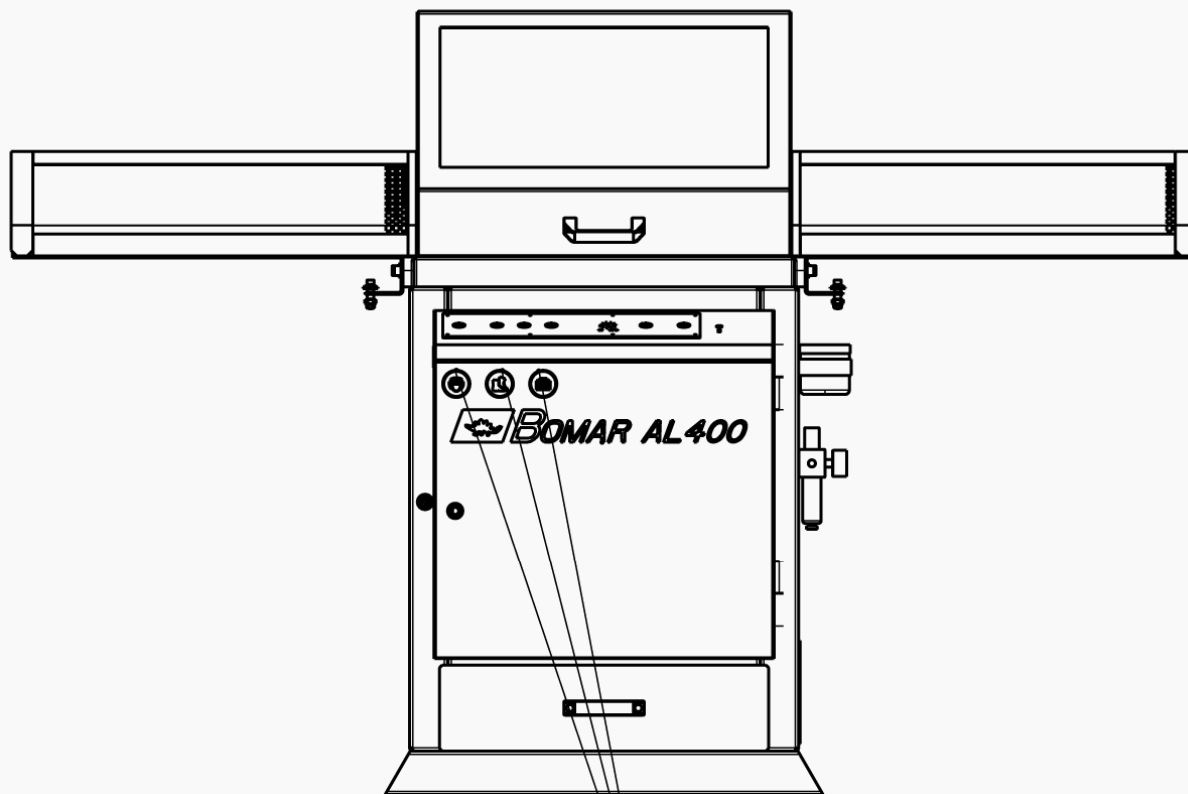

1.6. Umístění bezpečnostních značek /
Verteilung der Sicherheitszeichen /
Position of safety symbols



PO:
Noste pevnou pracovní obuv
Tragen Sie Sicherheitsschuhe
Wear fixed protective shoes

CZ:
Přečíst návod k použití
Bedienungsanleitung lesen
Read the operating instructions

OBS:
Noste ochranné brýle a sluchátka
Tragen Sie eine Schutzbrille und
Gehörschutz
Wear protective goggles
and headphones







HV
Hlavní vypínač
Hauptschalter
Main switch

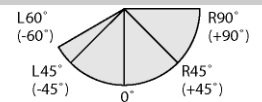

2. **Machine documentation**

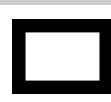
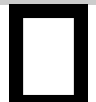
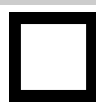
2.1. Technická data / Technische Daten / Technical data

Hmotnost stroje / Maschinengewicht / Machine weight:				
• Hmotnost / Gewicht / Weight	500 kg			
Rozměry stroje / Maschinengröße / Machine size :				
• Délka / Länge / Length	1100 mm			
• Šířka / Breite / Width	2350 mm			
• Výška / Höhe / Height	1560 mm / 2000 mm			
Elektrické vybavení / Elektrische Ausrüstung / Electrical equipment:				
• Napájení / Versorgungsspannung / Supply voltage	~3 x 400 V (230 V), 50Hz, TN-C-S/TN-C (dep. on saw ver.)			
• Příkon / Gesamtschlusswert / Total Input	5,1 kW			
• Max.jištění / Max. Vorschaltssicherung / Max. Fuse	16 A			
• Krytí / Schutzart / Protection	IP 54			
Akustický tlak / Schalldruckpegel / Acoustic pressure:				
• AL 500	$L_{Aeqv} = 76,3$ dB			
Pohon / Atrieb / Drive:				
• Typ / Typ / Type	1LA 7166 – 2AA10			
• Výkon / Leistung / Output	3,0 kW			
Pneum-Hydraulické zařízení / Pneumatik-Hydraulikeinrichtung / Pneum-Hydraulic equipment:				
• Typ / Typ / Type	k115-100			
Rozměr pásu / Sägebanddimension / Band size:				
Ø500 × Ø30 × 4,1 mm				
Řezná rychlost / Schnittgeschwindigkeit / Cutting speed:				
50 m/s (kotouč / rädern / blade Ø500)				
Řezné rozsahy / Schnittbereiche / Cutting size:				
				
L60° (-60°)	Ø120 mm	120×70 mm	55×170 mm	115×115 mm
0° (jaws in front)	Ø170 mm	265×25 mm	90×175 mm	155×155 mm
0° (jaws back)	Ø150 mm	295×70 mm	375×95 mm	95×95 mm
R45° (+45°)	Ø155 mm	280×50 mm	80×170 mm	130×130 mm
R60° (+60°)	Ø120 mm	120×70 mm	55×170 mm	115×115 mm
Level of acoustic pressure:				
Equivalent level of acoustic pressure A (noise) at operator position are $L_{Aeqv}=76,3$ dB. Mentioned values are levels of emission which doesn't have to represent safe levels. Factors which influence real level of acoustic pressure on machine operator are: working place characteristics, cut material, saw band. These factors have significantly influence on acoustic pressure.				

2.2. Řezné rozsahy /
Schnittbereiche /
Cutting sizes

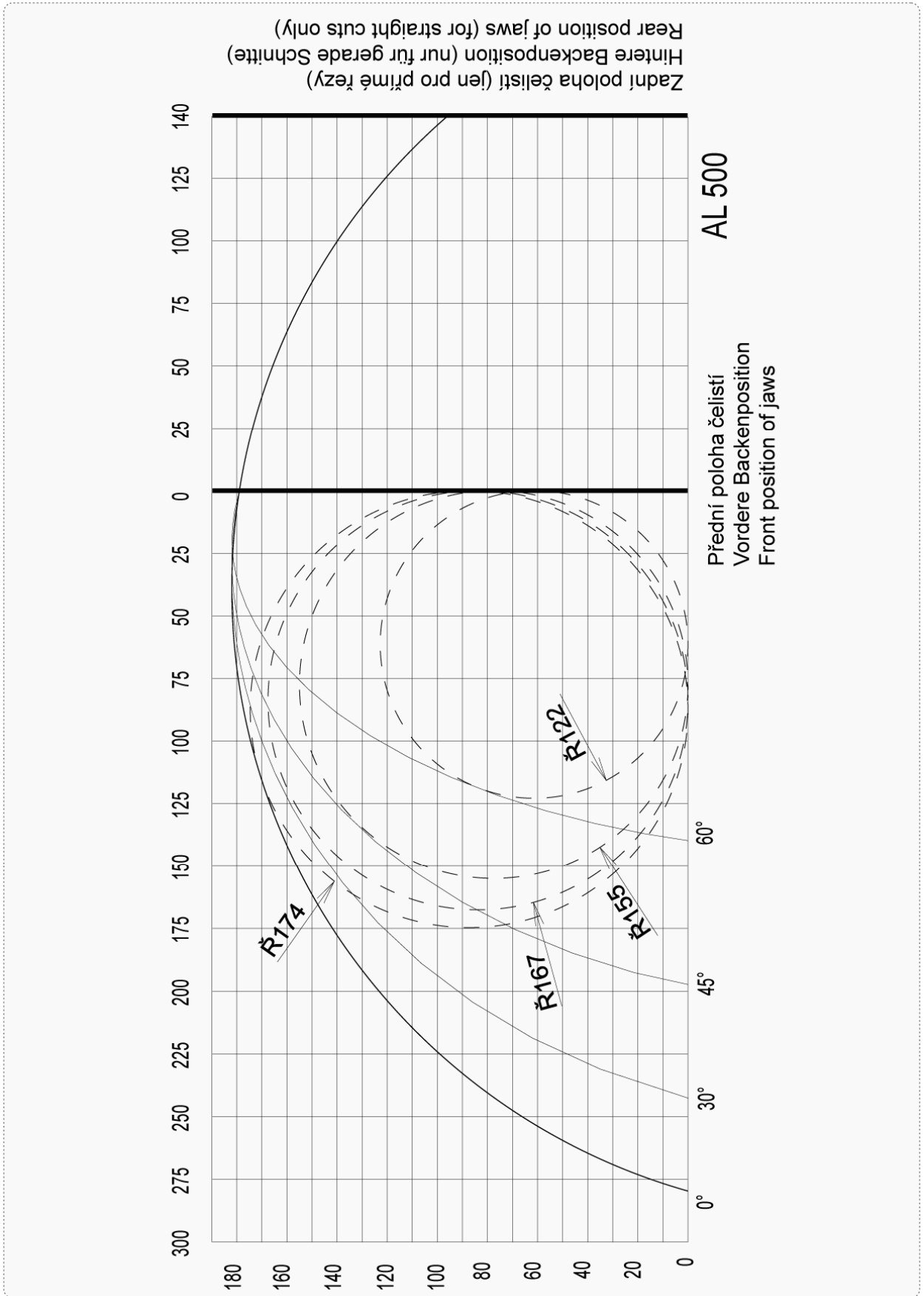

2.3. Rozměrové schéma /
Aufstellzeichnung /
Installation diagram

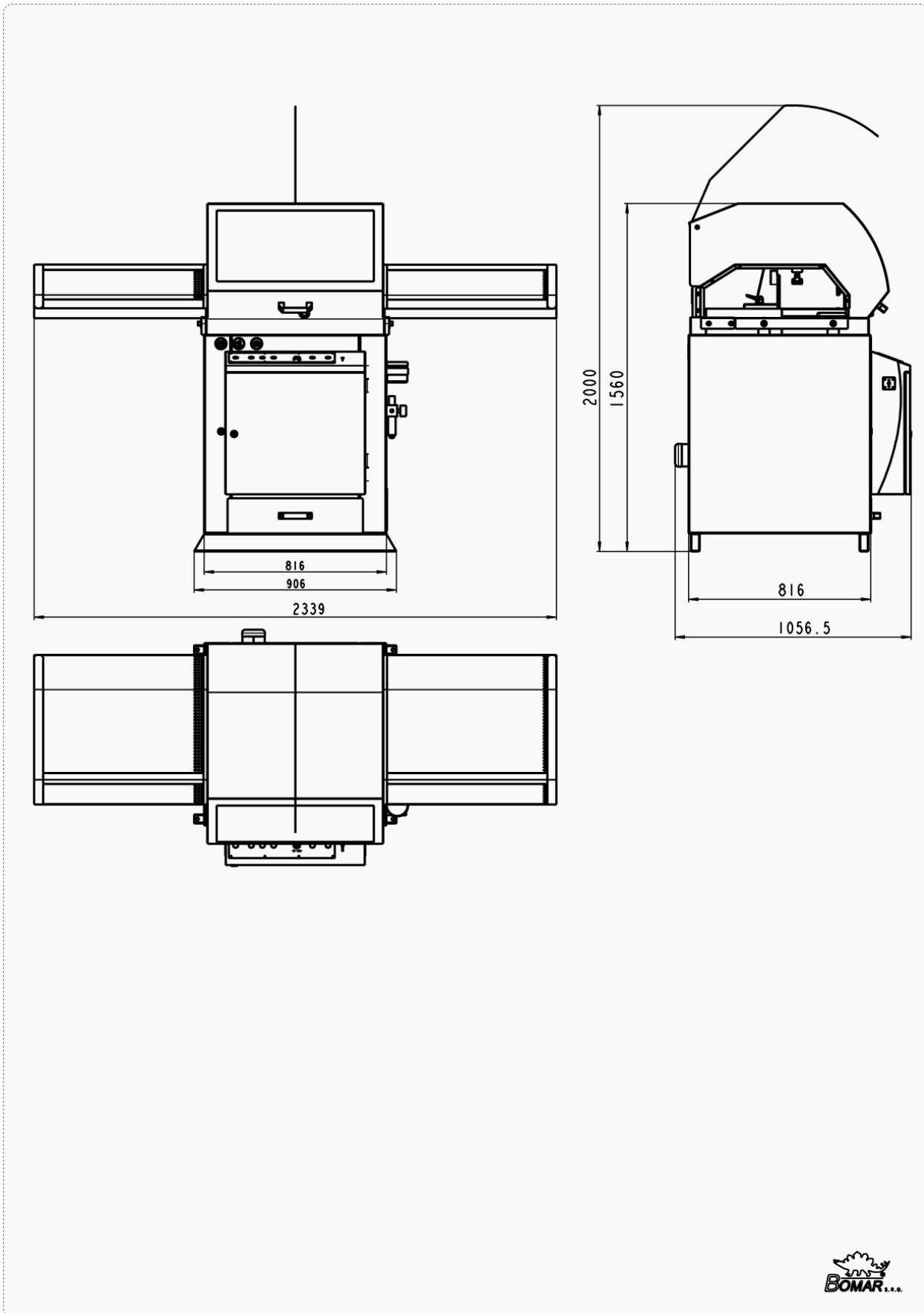

2.4. Popis /
Beschreibung /
Description

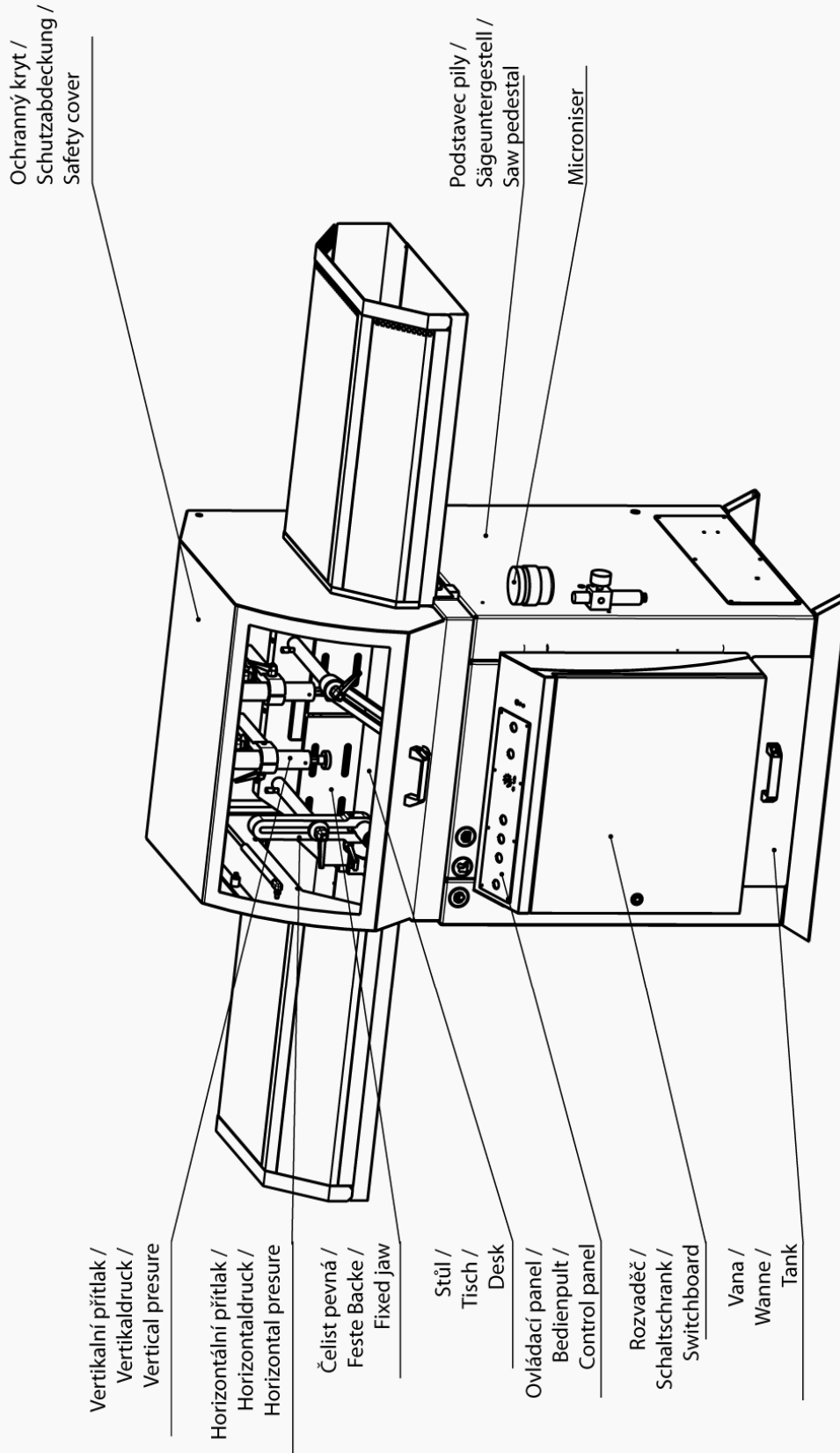

2.5. Transportation and stocking

2.5.1. Conditions for transportation and stocking

Keep recommendations for the manufacturers for transportation and stocking! If the recommendations are not kept, damage can occur to the machine.

- Don't use a forklift truck for handling the machine, if you do not have license for it!
- Don't move under suspended loads! Fault in lifting device may cause serious injury. Keep a safe distance from the machine during the transport.
- Temperature of the air from -25°C to 55°C , for a *short term* (max. 24 hours) temperature of the air until 70°C
- Do not expose the machine to radiation (for example microwave radiation, ultraviolet radiation, laser radiation, x-ray radiation). Radiation can cause problems with the machine function and deteriorating condition of the isolation.
- Take measures, to prevent damage by dampness, by vibrations and by shakes.

2.5.2. Transport and stocking preparations

- Close the vice and thoroughly oil all blank surfaces.
- Lower the saw frame to the lowest position.
- Fasten all loose parts securely to the machine.
- Pack and wrap the control desk securely to avoid damage during transport.

Fix the stickers stating the minimum approximate machine weight to at least five well visible places.

2.5.3. Transport and stocking

Handle the machine only with the hand pallet truck or the forklift truck! If the machine is equipped with the shackles in the pedestal, you can use the suspension cable and the crane.

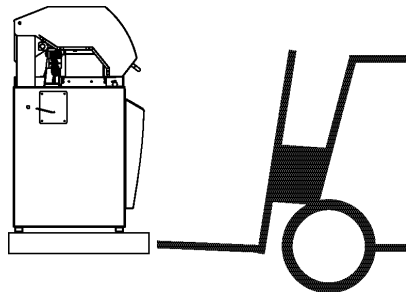

- Make sure that the hand pallet truck; the forklift truck or the crane had sufficient capacity.
- Make sure that the van or the trailer had sufficient capacity.
- The machine must be secured during transportation.
- Screw on the palette to the floor of the van or the trailer.
- Be careful that the machine is not damaged during transportation.

It is forbidden to handle the machine any other way, than it is written in this operating instructions, the machine can be damaged!

2.5.4. Transportní schéma /
Transport schema /
Transport scheme

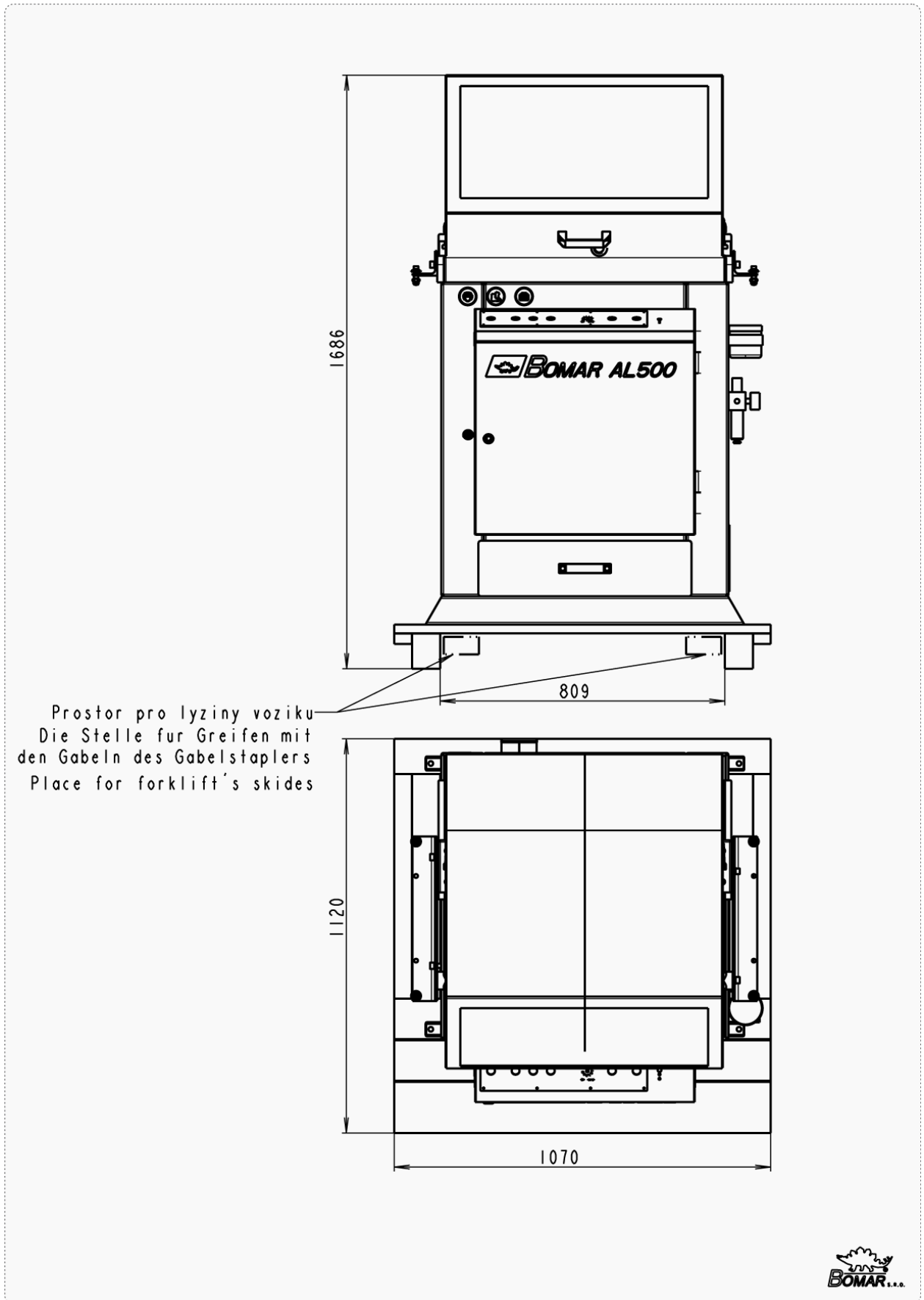

2.6. Activation

2.6.1. Machine working conditions

Keep the conditions of the manufacturer for machine operating! If recommendations are not kept, damage can occur to the machine.

The manufacturer warrants the correct function of the machine for these conditions:

- At temperature air from **5°C to 40°C**, the temperature average during 24 hours must **not exceed over 35°C**.
- At relative dampness of the air in the extend from 30% to 95% (not concentrate)
- Altitude lower than 1000 metres.
- Do not expose the machine to the radiation (for example microwave radiation, ultra-violet radiation, laser radiation, x-ray radiation). Radiation can cause problems with the machine function and deteriorating condition of the isolation.

2.7. Band saw unpacking and assembling

Remove the packing from the machine and unpack all parts.

Attention!

Note:

The socket with the fork can be used only at the machines with the rated current less than 16 A and total input less than 3 kW.

2.7.1. Machine installing and levelling

Check the floor supporting capacity before machine installing. If the floor capacity does not agree with requirements, you must prepare the necessary base for the machine.

Minimal requirement:

machine weight – AL 500 – 500 kg

+ weight of accessories

+ maximum weight of material

- The machine must be levelled at the horizontal position. All feet of the machine must touch with the floor after levelling
- The machine must be levelled by means of the calibrated spirit level. Spirit level is put on the vice area. Set the roller conveyors according to the spirit level.
- For machine levelling, take care that there is sufficient available space for operation, repair work, servicing of the machine and handling the material.
- The machine including appended parts and accessories must be visible from the place of operation.

2.7.2. Machine disposal after lifetime

Blown out all service fluids (cooling liquid, hydraulic oil) into designated reservoir. Dismantle machine into separate parts and dispose them in accordance with valid directives.

2.7.3. Kotevní plan / Verankerungsplan / Grounding plan

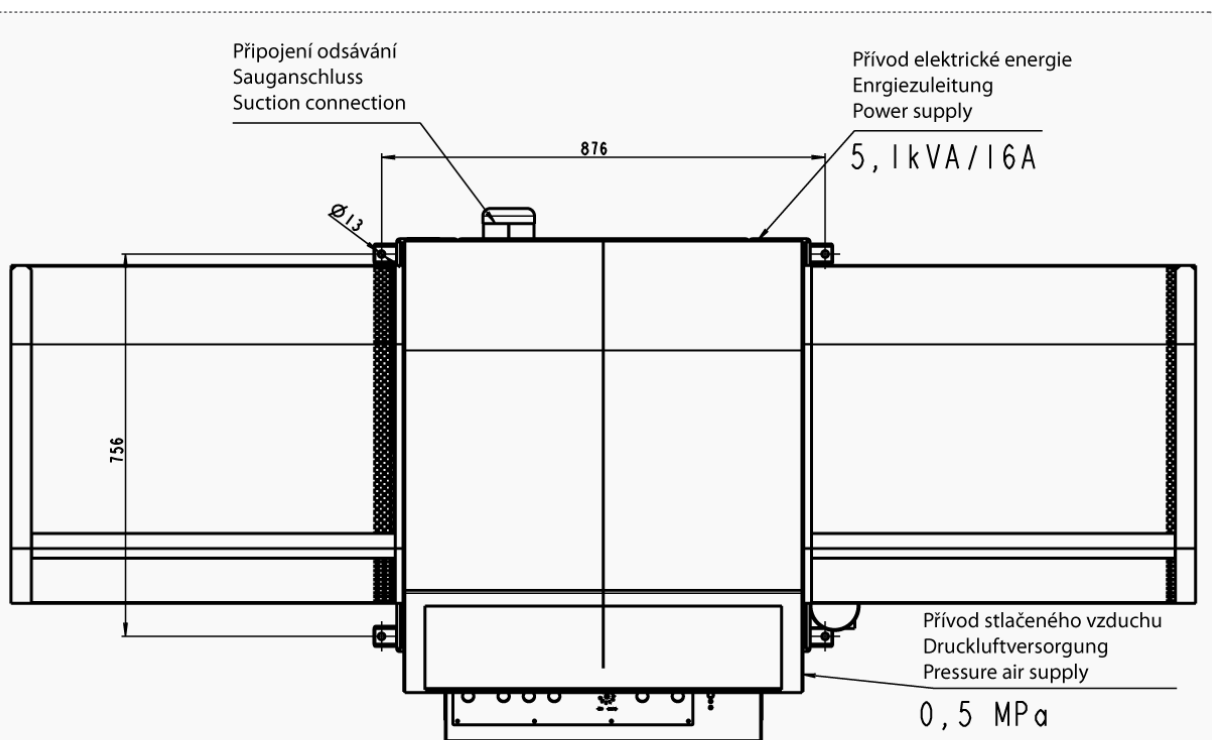

Kotvící materiál / Verankerungsmaterial / Grouding material

- Hmoždina / Dübel / Plug – 4x $\varnothing 12$ mm
- Vrtáno do hloubky / In die Tiefe gebohrt / Drilled to – 120 mm
- Šrouby / Schraube / Screws – 4x M10

- Šrouby podložit deskami o min. rozměrech P10x100-100
- Die Schrauben mit Platten mit Minimaldimensionen P10x100-100 unterlegen
- Screws must be bottomed with plates (min. dimensions P10x100-100)

Požadavky na rovinnost podlahy / Anforderungen an die Bodenebenheit / Requirements for floor flatness

± 10 mm / 1 m

2.8. Electrical connection

Attention!

Only a qualified professional must carry out the servicing and repairs of the electric equipment! Take special care during work with electrical equipment. High voltage shock can have fatal consequences! Always keep notes about work safety.

Electrical parameters of the machine:

- Service voltage: ~3 x 400 V (230 V), 50Hz, TN-C-S/TN-C (dep. on saw ver.)
- Total input / Max. fuse: 5,1 kW / 16 A
- Before connecting switch off the main switch of the power supply circuit for the machine and ensure dry place when doing connecting works!

Note:

The values of the crosscut of the conductor and the rated current are in the norms.

- Service voltage must agree with the line voltage! Crosscut of the supply line must respond with rated current for max. machine load.

Note:

The socket with the fork can be used only at the machines with the rated current less than 16 A and total input less than 3 kW.

- In case the machine is connected with a direct connection, an extra main switch must be added which can be locked in zero position.

Attention!

In this case the extra main switch becomes primary and the main switch on the machine has only secondary function.

2.8.1. Check the running direction of the cutting wheel

After the machine has been successfully connected, briefly switch on the machine and put the driving engine of the cutting wheel in the running position. The direction must be in accordance with the arrow direction on the picture. In case the direction of the cutting wheel does not match, two phases at the terminal strip must be switched.

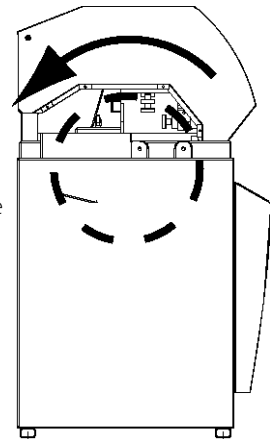

2.9. Connecting to the compressed air supply

Connect the machine to the compressed air supply by means of the screw **G1/4** on the manifold period according to the picture.



Compressed air must satisfy conditions:

- Roughly cleaned and partly dry.
- $p_{min} = 0,4 \text{ MPa} = 4 \text{ bar}$

- $p_{max} = 0,6 \text{ MPa} = 6 \text{ bar}$

2.10. Filling of the cooling system

Note:

If the machine is equipped with Microniser, fill the Microniser container with prescribed cooling agent. Now is Microniser ready for operation.

2.11. Check machine function

Before starting the check machine functions, you must read the chapter „**Machine operation**“. Do not carry out check machine functions, if you do not comprehend meaning of all buttons and all machine functions.

Check, if the machine or some parts of the machine were not damaged during transport.

Check, if covers are installed and functional.

Switch on the main switch and check the motors and systems (saw disk drive etc.).

Open and close the vice. Turn the saw frame from one outer position to other outer position. Raise the frame to the top position and drop the frame to the lowest position.

Carry one cycle of cutting without material. Check, if the machine runs with no irregularities. If all machine functions are right, the machine is ready for operation.

2.12. Saw blade

Refit the saw band cover only after you have installed and tightened the saw band.

2.12.1. Saw blade size

Ø500 × Ø30 × 4,1 mm

The maximum cutting range of the machine is reached by using diving disk with recommended diameter. The usable qualities of the machine are lowered by using diving disk with fewer diameter.

Usage of the dividing disk with fewer diameter than 350 mm is not recommended!

2.12.2. Selection of the saw disk

The circular disk is possible to equip with dividing disks according to the material character and requirements on the quality of cut.

Look at the recommendation of your supplier when selecting the suitable dividing disk.



Note: *The machine is supplied without the saw disk.*

3. **Machine control**

3.1. Starting the saw

- »
- Switch on the main switch of the band saw. The main switch is situated on the side of the switchboard.



3.2. Control panel

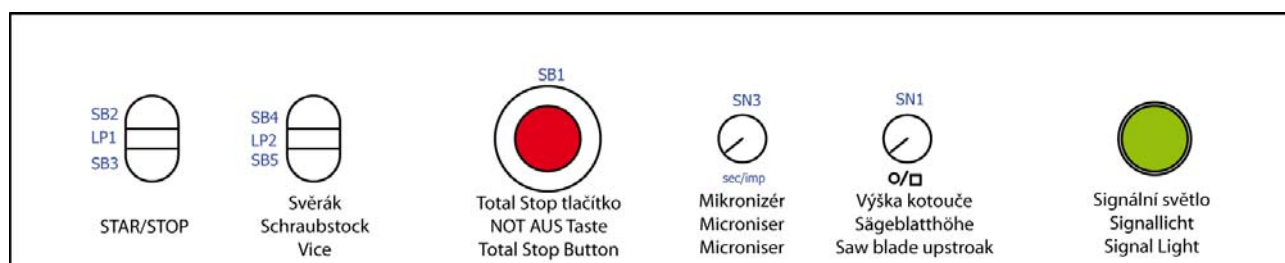

SB1	TOTAL - STOP In case of emergency, the machine is stated to the order!
SB2 SB3	START / STOP Press to start or stop machine working cycle.
SB4 SB5	Clamp / open vice
SN3	Microniser Adjust the time between the two potions (injections) of cooling liquid (1-10 seconds). When the time between the two potions is shorter, the cooling is more intensive.
SN1	Adjusting wheel Turn to set the height of the circular-saw blade according to the profile of the cutting material.
	Control valve (not shown on picture) It adjusts the shift speed of the disk to the cut. Notice: If you keep closing the throttle valve too tightly, the valve seat may wear off which causes its leakage. Therefore, close the valve always gently.

3.3. Machine control

- Adjust the desired cutting angle.
- Insert profile with the cover open.
- Adjust height of circular blade with SN1 according of cutted profile

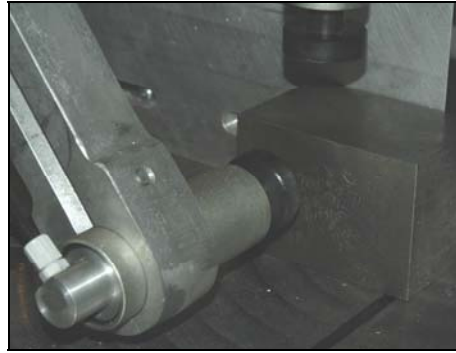

4. Set the clamping cylinder closest to the material (recommended value is 20 mm). If the clamping cylinders are further away from the material, the clamping takes longer.
5. Press and hold the button SB4 (clamping vice) for material clamping (the saw cover is still open). For security reasons, clamping pressure is limited, when is safety cover opened.
6. Close the saw cover.
7. Press button START (SB2) to start cutting cycle. When is START button pressed material is clamped with full pressure.
8. The cycle is completed after cutting, saw cover is unlocked and material is released from vice.
9. Remove the material and the whole working cycle can be repeated.

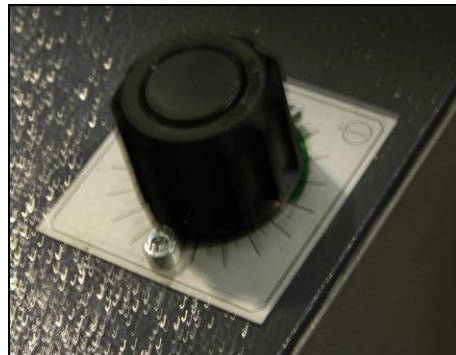

Desired speed lifting arm to cut set by Control valve.

3.3.1. Signal light

- **Green** – upper cover unlocked
- **Red** – upper cover locked
- **Red blinking** – FAILURE (engine heat protection, opened covers, opened doors, Total Stop button)

3.3.2. Cycle breaking

The cycle can be stopped by 2 ways:

- Release both buttons **Cutting (1)** and press **STOP** button (button **5** – control panel) – the saw interrupts the actual cut, the saw arm lifts to the starting position and the saw disk drive stops.
- Press emergency button **TOTAL STOP** (button 3 – control panel) in emergency causes! The safety circuit is broken and the saw disk drive is stopped too.

3.4. Circular saw adjusting

3.4.1. Set of clamping cylinders

Security hole at maximum retract the rod.

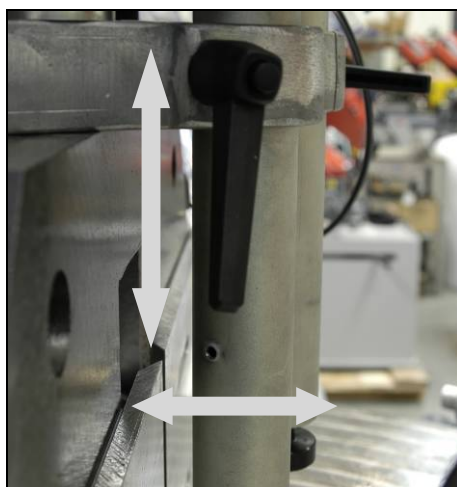

- When adjusting the height of the cylinder bore, the hole must be directed from the service. When removing the cylinder bore must be directed into the groove clamp.
- Material can be clamped main cylinder or two cylinders. Main clamping cylinder with a pressure switch (left from the perspective of the machine service)
- The cylinder can be adjusted from 20 mm to 100 mm from the cut material!
- If no possible clamping of the material at the maximum protrusion of clamping cylinders, not to run the operating cycle.

Attention!

If the main cylinder to clamp the material being cut off (eg. the table) can be runcycle.

3.4.2. Jaw console setting

Normally, the jaw console is situated in the front position. At cutting with 0° angle, the cutting range can be increased by shifting with console to the back.

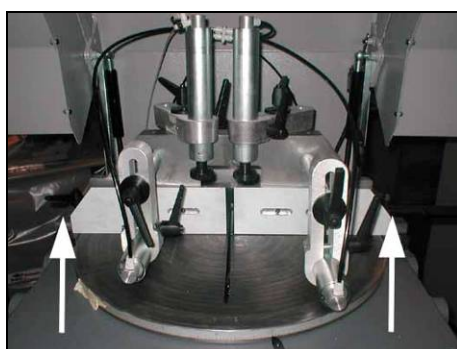

1. Loosen the tightening levers of the console.
2. Move the jaw console as far as the rear stops.
3. Tighten the securing levers of the jaw console.

ATTENTION! *At angular cuts, console with jaws must be situated in front!*

ATTENTION! With chips collector device installed on table, the cut angle can be varied from -60° to 60° .

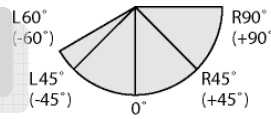

3.4.3. Angular cut setting

The cut angle can be varied from -60° (L60°) to $+90^\circ$ (R90°).

ATTENTION! At angular cuts, console with jaws must be situated in front!

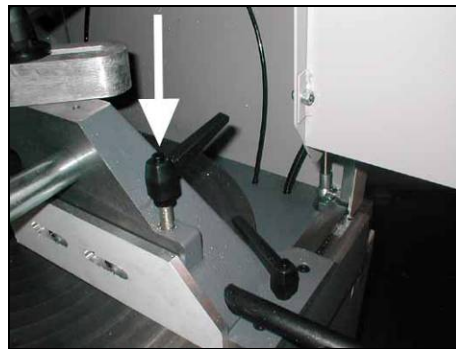

1. Release the securing lever of the turning console and adjust the desired cutting angle according to the scale.

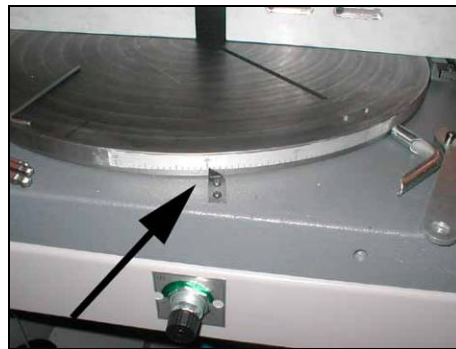

2. The scale is situated on the side of the turning console. Tighten again the securing levers of the turning console.

3.4.4. Clamping adjusting

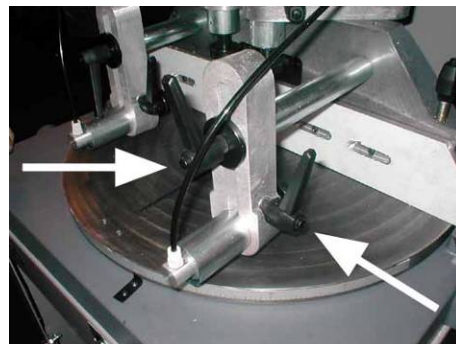

1. Release the securing lever of the clamping cylinder.

2. Shift the clamping cylinder. The clamping vice must be situated about 10 mm from the material.

3. Tighten again the securing lever.

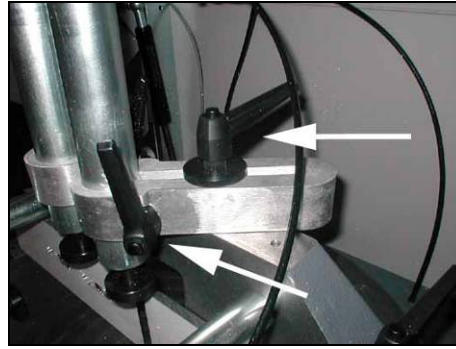

4. Adjust all four clamping cylinders.

3.4.5. Speed adjusting of the arm lowering

Set the speed of the arm lowering to the cut by control valve (position 7 – control panel).

- Set the **lower** speed of the arm lowering to the cut by turning the switch **clockwise**.
- Set the **higher** speed of the arm lowering to the cut by turning the switch **anti-clockwise**.

Notice: If you keep closing the throttle valve too tightly, the valve seat may wear off which causes its leakage. Therefore, close the valve always gently.

3.5. Exhausting device (optional accessories)

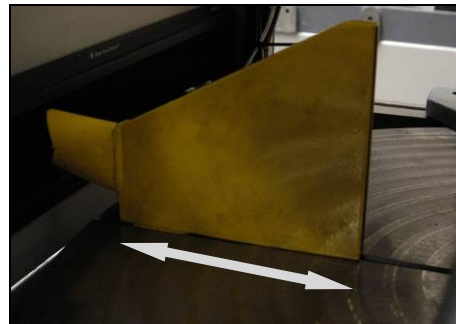

If a chip collector is installed on the saw table, it is necessary to move it according to the setting of the saw blade stroke (saw blade stroke is set by SN1 on the control panel).

- Big saw blade stroke – chip collector to move the most backward
- Low blade stroke – chip collector to move the most forward
- With the chip collector device installed on the table, the cut angle can be varied from -60° to 60° .

3.6. Material insertion

- Never walk under a suspended load!
- Never climb onto the gravity-roller conveyor!
- Do not hold the material for clamping material to the vice! The vice can cause injury!

3.6.1. Handling agent selection

- Use the strong handling agents to lift and transfer the material!
- Handle with the material only with the lift truck or use the suspension strands and the crane!
- Do not use the lift truck or crane in case that you do not have the license to handle with it!

3.6.2. Insertion

Insert material to the vice and ensure that the material cannot move in the vice or fall from the vice after the clamping. If you cut long pieces of the material (for example rod, tube), you must use the roller conveyors for material shifting to the band saw. Contact Bomar for more information about roller conveyors

Make sure the conveyor is long enough and the material cannot tip off the conveyor.

Be especially careful with round materials that it always stays on two vertical rollers and that it cannot fall off the conveyor!

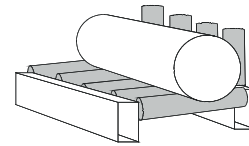

4. Machine service

4.1. Saw disk dismantling

WARNING!

After switching off the machine, the blade will still rotate for at least one minute. **Opening the door in this time is not allowed and can cause serious injuries!**

Doors are secured with a lock. Approximately 50 s after the last cutting machine doors are unlocked. The machine must be connected to the network and turned on



1. Wait for the door unlock and open it. Saw is switch ON.
2. Switch the main switch off.



3. If your saw has exhausting device installed, before removing saw blade, remove exhausting device from blade. Dismount plastic screw.

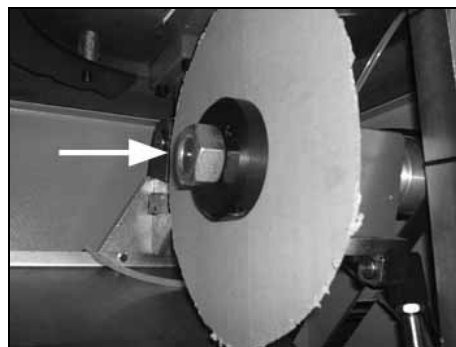

4. Loose the nut, get off the washer and the saw disk.

4.2. Saw disk installation

1. Prior to installation, clean the shaft thoroughly of all traces of chips and dirt. Keep in mind **the teeth direction when installing the saw disk.**
2. Put on the saw disk and the washer. Tighten the nut fast.
3. Close the door at the pedestal.
4. Switch the main switch on. The circular saw is set up.

4.3. Cooling agents and chips disposal

The quality of the cooling agent will deteriorate due to:	If the solution is too weak:	If the solution is too strong:
<ul style="list-style-type: none"> • use of contaminated water • impurity • outside oil contamination (hydraulics, gears) • high operating temperatures • lack of air circulation • wrong concentration 	<ul style="list-style-type: none"> • corrosion protection is diminished • lubrication decreases • microbial attack is more likely 	<ul style="list-style-type: none"> • the cooling ability is decreased • foam behaviour increases • emulsions stability deteriorates • sticky residue develops

4.3.1. Cooling liquid inspection

Check the state of the cooling liquid periodically. Keep notes in chapter **Cooling agents and chips removal** for state checking and cooling liquid filling.

If the cooling liquid is little in the tank, it can cause the damage of the saw disk by influence of insufficient cooling.

The excess liquid can overflow from the tank on the floor, the service worker can slide and he can injure.

4.3.2. Chips disposal

Chips resulting from cutting operations must be disposed of in accordance with the relevant regulations.

- Let the chips drip excess fluid!
- Fill a watertight container with the chips! Be careful that the container does not leak, because even after a long dripping time, they still contain coolant residue.
- *Place the container into the care of a disposal company equipped for the disposal of chips contaminated with cooling liquid.* In case the machine is equipped with micro-spray installation, the chips must also be handed over to a disposal company.

4.4. Hydraulic, Greases and oils

4.4.1. Lubricant greases

We recommend using lithium based saponified grease, class NGLI-2 for lubrication. Different greases are mixable, if their oil bases and consistence type are identical.

Comparative table of the lubricant greases:

Manufacturer	Type of the lubricant grease
BP	Energrease LS - EP
DEA	Paragon EP1
Esso	FETT EGL 3144
	Beacon EP 1
FINA	Beacon EP 2
	FINA LICAL M12
Klüber	Microlube GB0
	Staburags NBU8EP
	Isoflex Spezial
Optimol	Optimol Longtime PD 0, PD1, PD2
Shell Aseol AG	ASEOL Litea EP 806-077
Texaco	Multifak EP1

4.4.2. Lubrication

There are several places on the machine, which are necessary to grease periodically. It secures the right function of the machine.

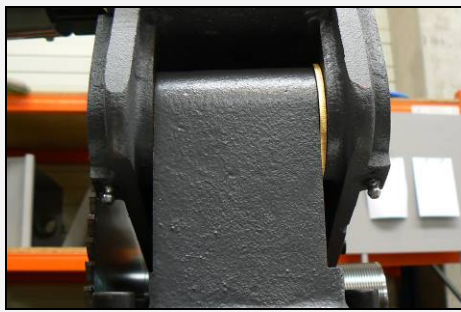
Lubrication place	Lubrication
	<p>Concole of the saw arm – lubricate with grease once per month (see chapter Lubricant greases). Use 3-5g grease on the every carriage of the linear guiding. Use the grease gun to the lubrication. Drive 3-5 times whole line of the linear guiding during lubrication.</p>

4.4.3. Hydraulic oils

Replace the hydraulic oil once in 2 years, because the oil can deteriorate its properties and cause problems the hydraulic equipment. If the hydraulic system is equipped with filter (2SF 56/48-0,063), replace the filter too.

Use oils with specification DIN 51524-HLP, ISO 6743-4 and viscosity grade ISO VG 46 in hydraulic aggregates. Hydraulic oils quantity – see chapter **Hydraulic oil level check**.

Note:

When replacing, use oils recommended by BOMAR or oils, which has comparable parameters from the other manufacturers. Do not forget, that mineral and synthetic oils may not be mixed!

Comparative table of the hydraulic oils

Manufacturer	Type	Manufacturer	Type
Agip	Oso 46	Ina	Hidraol 46 HD
Aral	Vitam GF 46	Klüber	Lamora HLP 46
Avia	Avilub RSL 46	Hungary	Hidrokomol P 46
Benzina	OH-HM 46	Mobil	Mobil DTE 25
BP	Energol HLP 46	ÖMV	HLP 46
Bulgaria	MX-M/46	Poland	Hydrol 30
Castrol	Hyspin AWS 46	Rumania	H 46 EP
Čepro	Mogul HM 46	Russia	IGP 30
DEA	Astron HLP 4hy6	Shell	Tellus Oil 46
Elf	Elfolna 46	Sun	Sunvis 846 WR
Esso	Nuto H 46	Texaco	Rando HD B 46
Fam	HD 5040	Valvoline	Ultramax AW 46
Fina	Hydran 46		

4.4.4. Hydraulic oil level check

Open the door at the pedestal and check the state of the oil. The oil level must be situated between marks **min** and **max**.



Fill the hydraulic oil, if it is necessary. Use always the filter (10 μm or better) when you fill the oil. You avoid impurities penetration to the hydraulic system and troubles in hydraulic system.

4.5. Pressure system servicing

Filter of the pressure system is necessary to clean periodically, that means drain sediments and impurities from the reservoir.

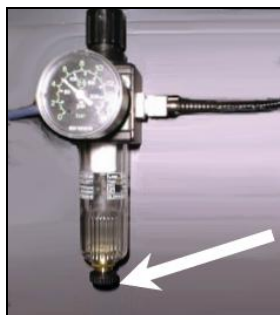

Screw off the screw and let to drain sediments to the reservoir. Screw on the screw again.

WARNING!

There is a pressure 0,5 – 0,6 MPa in the system, therefore you must release the screw very carefully!

4.6. Machine cleaning

Clean the machine from the cooling liquid and impurities after every shift stopping. Conserve the guiding surfaces, mainly:

- Clamping jaws of the vice.
- The guiding of the jaws' console.
- Loading surface and area in the pedestal.

4.7. Worn pieces replacement

4.7.1. Belt replacement

1. Switch off the machine main switch.
2. Open the door on the pedestal.

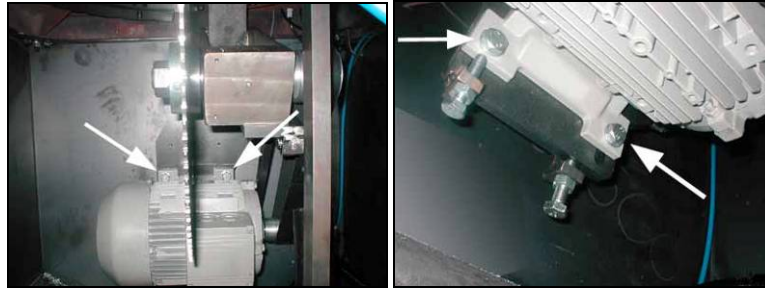

3. Release 4 screws, which holds the electromotor.

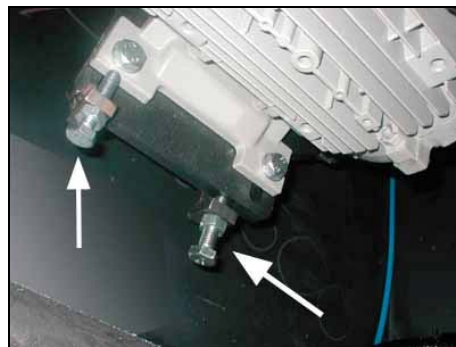

4. Release nuts of the stretching screws and screw off both screws, until the belt is not released.

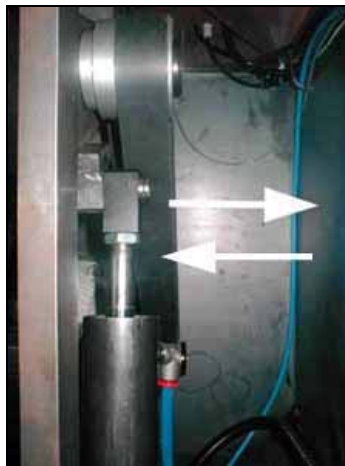

5. Remove worn driving belt and put on the new.

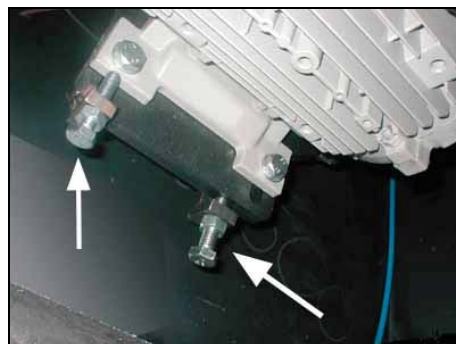

6. Stretch the driving belt by means of the stretching screws and tighten nuts of the stretching screws again.

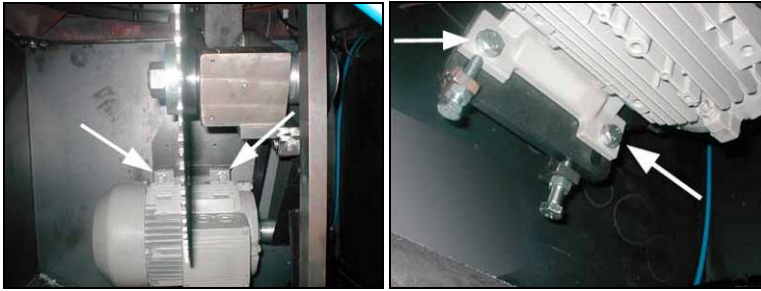

7. Tighten 4 screws, which holds electromotor.
8. Close the door on the pedestal and switch on the main switch. Belt replacement is finished.

5. **Schémata / Schemas / Schematics**

5.1. Elektrické schéma / Elektroschema / Wiring diagrams

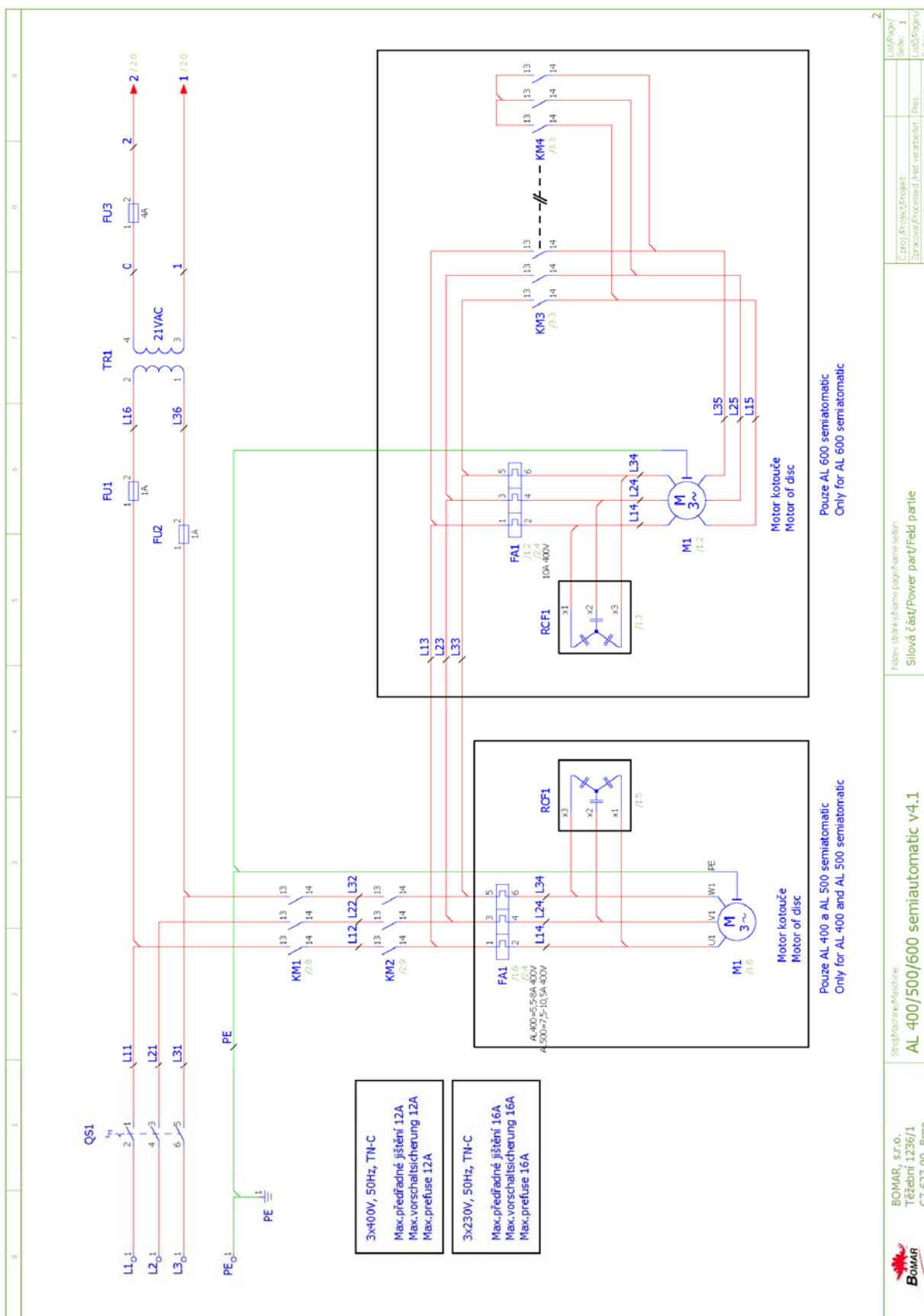

0 1 2 3 4 5 6 7 8 9	QS1 L1_1, L2_1, L3_1 PE	FU1, FU2, FU3 TR1 L11, L21, L31 PE	KM1, KM2 L12, L22, L32 RKF1 FA1 M1	L13, L23, L33 KM3, KM4 L14, L24, L34 M1	L35, L25, L15 Motor kotouče Motor of disc
---------------------	-------------------------------	---	--	--	---

**Schemata
Schemata
Schematics**

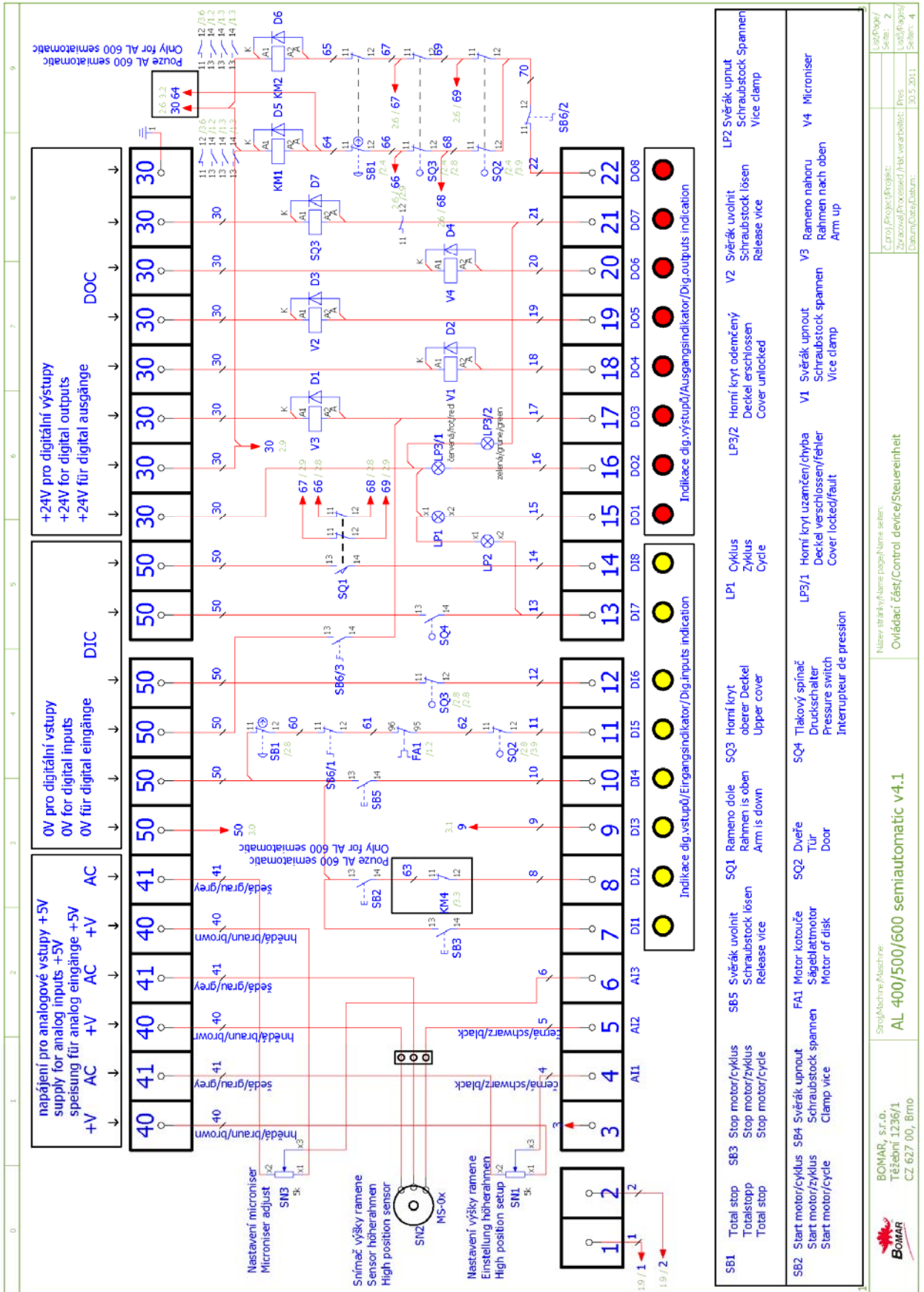

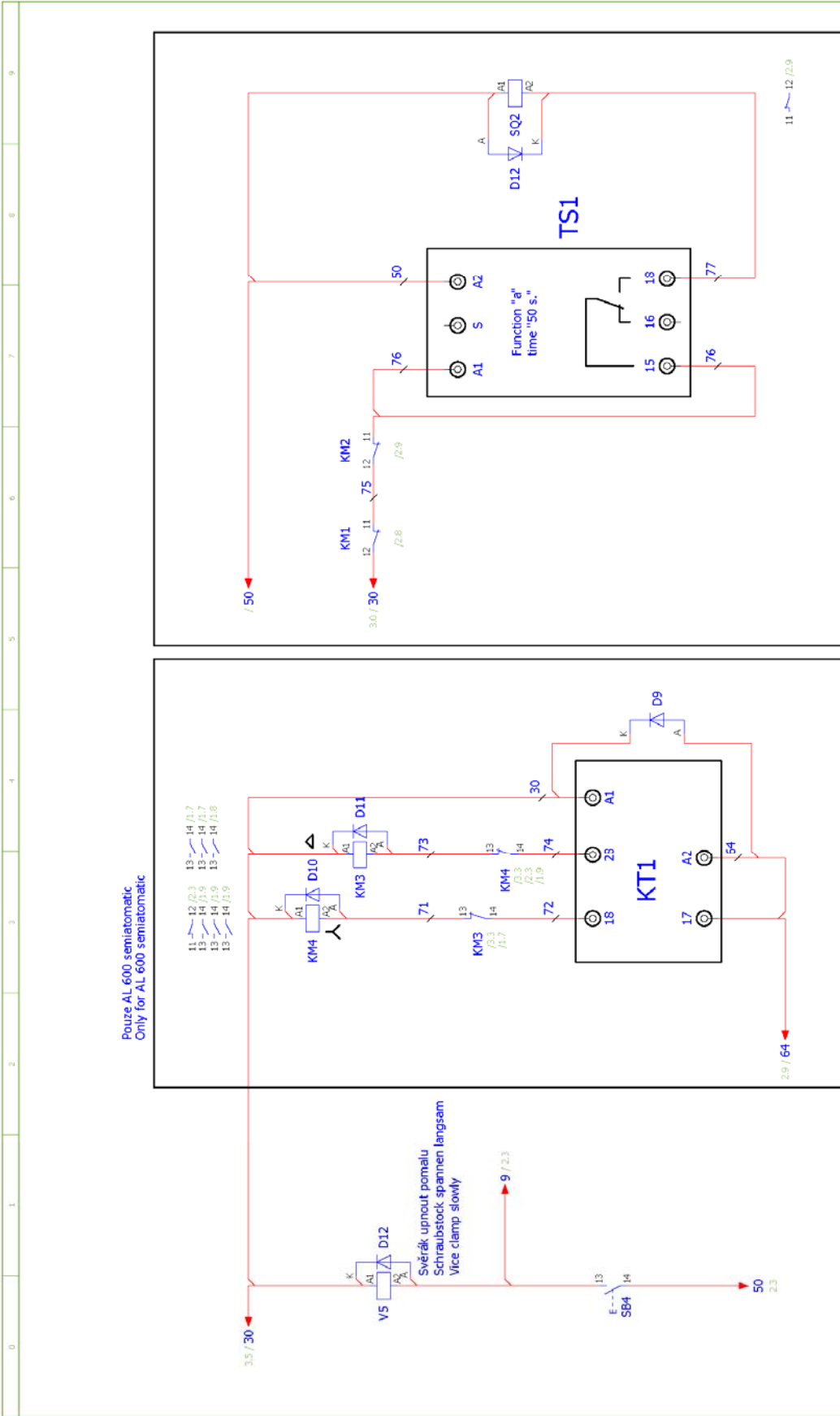

2	 BOMAR, s.r.o. Těžební 1236/1 CZ 627 00, Brno	Stroj/Machine/Machine: AL 400/500/600 semiautomatic v4.1	Název stránky/Name page/Name sheet: Ovládací část/Control device/Steuerinheit	Číslo/Project/Projekt: Zpracováno/Processed/Hat verarbeitet: Pries Datum/Date/Datum: 30.5.2011	List/Page/ Sheet: 3 List/Page/ Sheet: 4
---	---	--	---	--	--

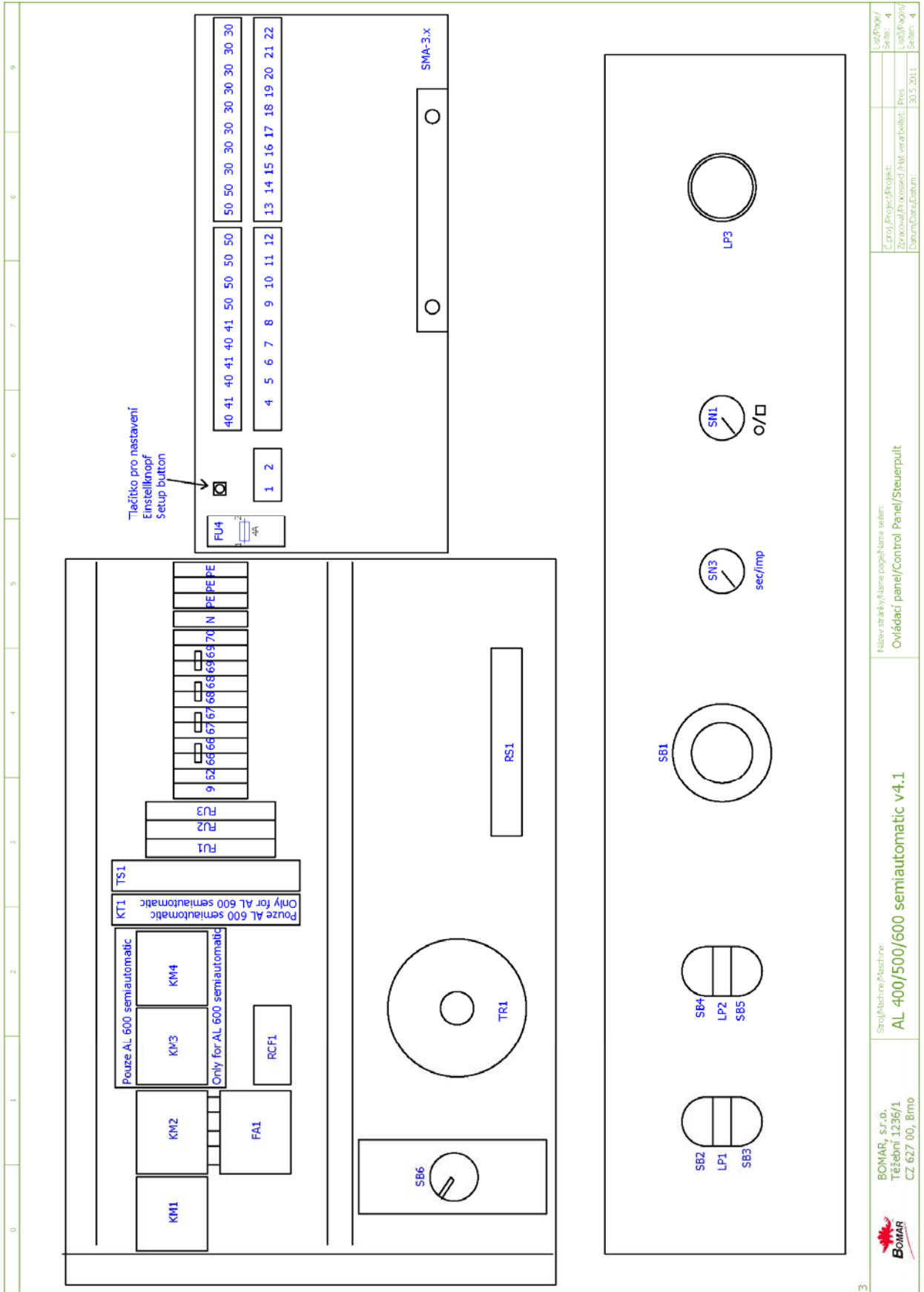

Název stroje/Name page/Name series: Ovládací panel/Control Panel/Steuerpult		List/Page/ Series: 4
Stroj/Machine/Modeline: AL 400/500/600 semiautomatic v4.1		C_proj/Project/Projekt: Zpracoval/Processed/Hat verarbeit: Datum/Data/Datum: 30.5.2011
BOMAR, s.r.o. Těšební 1236/1 CZ 627 00, Břmo	BOMAR, s.r.o. Těšební 1236/1 CZ 627 00, Břmo	List/Page/ Series: 4 List/Page/ Series: 4

5.2. Pneumaticko-hydraulické schéma / Pneumatik-Hydraulikschema / Pneumatic-Hydraulic diagram

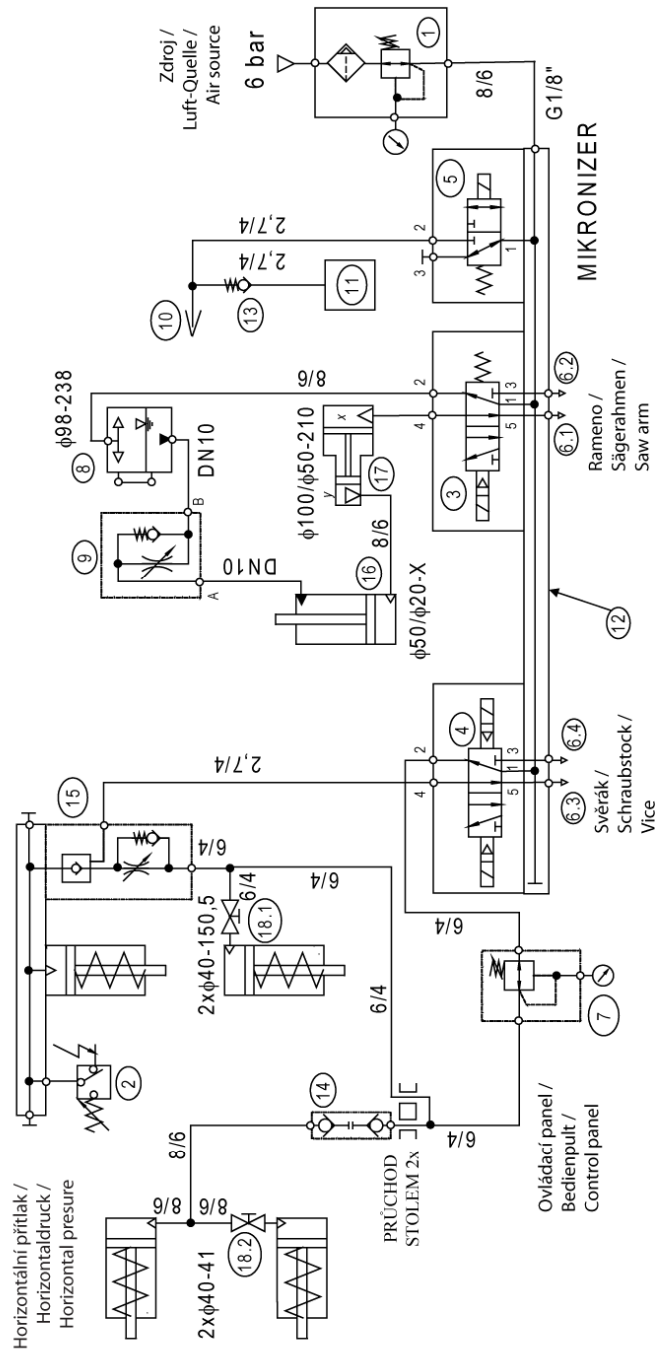

17 Pouze u /
nur /
only ALU-600

DN10 Hydraulická hadice /
Hydraulikschlauch /
Hydraulic hose PN 40bar

Hydraulický olej /
Hydrauliköl /
Hydraulic oil
HLP46
na úseku /
zwischen /
in section 8 - 16

Základní technické parametry
Technische Spezifikation
Technical specification

Typ / Type / Type	AL400, AL500, A600
Hydraulický agregát / Hydroaggregat Hydro aggregat	
Neuvedené světlosti / Unerwähnt Lichtbreite Unlisted inside diameters	JS6
Výstupní šroubení / Ausgangsschraubung Output screwing	G1/4"

Poz.	Název položky		ks
Pos.	Bezeichnung		Menge
Pos.	Item		Pcs.
1	Redukční ventil / Reduktionsventil / Control valve	93.003.001	1
2	Tlakový spínač / Druckschalter / Pressure switch	92.201.004	1
3	Rozvaděč / Verteilungsventil / Distributor	93.002.003	1
4	Rozvaděč / Verteilungsventil / Distributor	30.1505-704	1
5	Rozvaděč / Verteilungsventil / Distributor	93.001.0	4
6	Tlumič / Dämpfer / Inhibitor	93.014.003 G1/8"	2
7	Redukční ventil / Reduktionsventil / Control valv	93.002.004	1(0)
8	Výměník / AUSTAUSCHER / exchanger	201.K107-300 V=1,785dm ³	1
9	Škrťací ventil / Drosselventil / Throttle-valve	92.152.013 (ALU 400,500) VS01-04/R3,5-O6S 92.152.011 (ALU 600) VS01-04/R3,5-O6	1
10	MIKRONIZER	99.150.002	1
11	Nádrž / Behälter / Tank	94.404.001 0,5dm ³	1
12	Rozvaděč / Verteilungsventil / Distributor	30.0915-101	1
13	Jednosměrný ventil / Einwegventil / One-way valve	93.024.001	1
14	Rychlospojka / Schnellkupplung / Gladhand	93.023.001/002	1
15	Ventil pojistný / Sicherungsventil / Retaining valve	93.021.002 SMC JAPAN	1
16	Zvedací válec / Hubzylinder / Lifting cylinder	201.K107-000 (ALU400) X=175 201.K307-000 (ALU500) X=228 201.K407-000 (ALU600) X=173	1
17	MULTIPLIKÁTOR (4x)	201.K415-000 Only AL 600	1
18	Ventil uzavírací / Ventil / Valve	99.260.001	2(1)
19	Ventil / Ventil / Valve		1
20	Škrťací ventil / Drosselventil / Throttle-valve	93.021.011	1

6. **Výkresy sestav pro objednání náhradních dílů / Zeichnungen für Bestellung der Ersatzteile / Drawing assemblies for spare parts order**

- Při objednávání náhradních dílů vždy uvádějte: typ stroje (např. practix AL 500) , výrobní číslo (např. 125) a rok výroby (např. 1999).
- In die Bestellung der Ersatzteile führen Sie immer an: Maschinentyp (z. B. AL 500), Serien Nr. (z. B. 125) und Baujahr (z. B. 1999).
- For spare parts order, you must always to allege: type of machine (for example AL 500), serial number (for example 125, see cover page) and year of construction (for example 1999).

6.1. AL 500

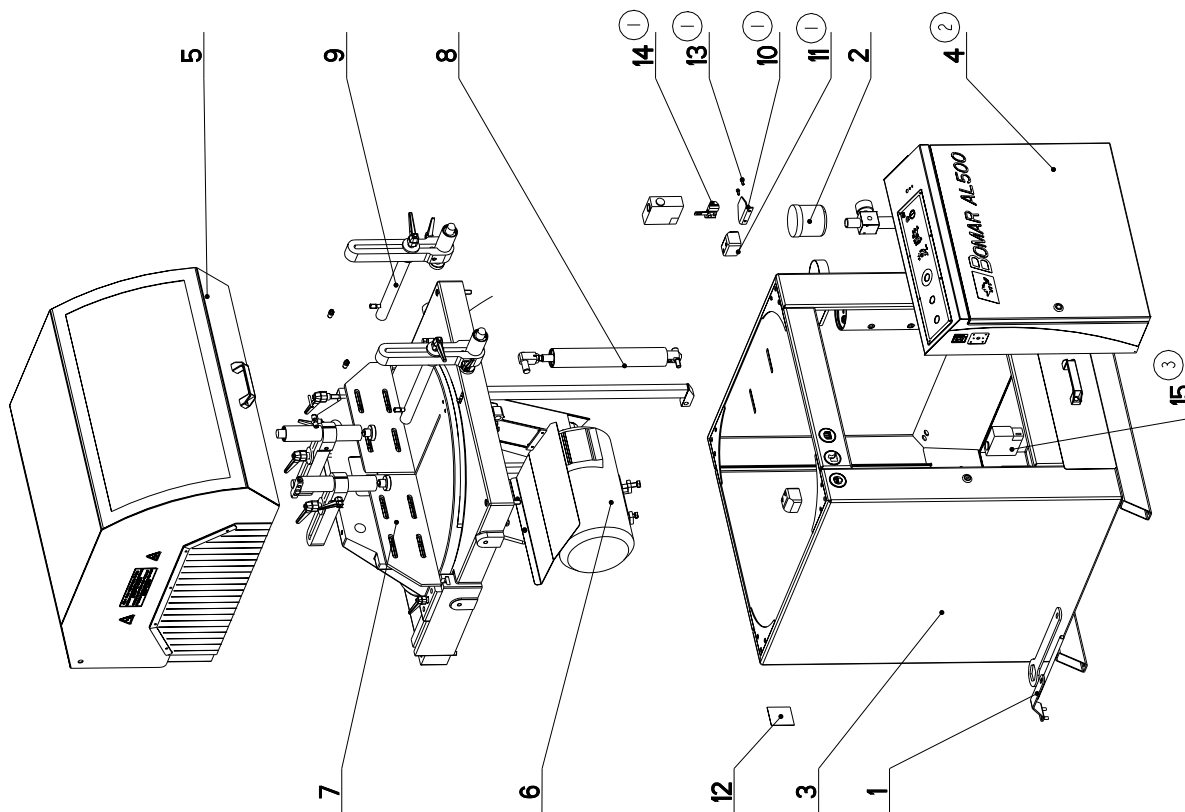

	NAZEV SESTAVY PILA KOTOUCOVA	CÍSLO SESTAVY 201.K300-100	STROJ AL500
	Konstruoval: HERALT		
Datum: 01. 09.2011			Meritko: 2:25

6.2. Kusovník / Stückliste / Piece list – AL 500

Císlo Sestavy 201.K300-100		Název sestavy PILA KOTOUČOVÁ/ROTARY SAW/KREISSÄGE	
Poz.	Objednací číslo	Ver.	Ks
1	201.K114-100	0	
			KLIC / KEY / SCHLÜSSEL
2	201.K116-000	1	
			PNEUMATIKA / TYRE / PNEUMATIK
3	201.K301-100	1	
			PODSTAVEC / BASE / UNTERSATZ
4	201.K301-220 (2)	0	
			ROZVADEC / DISTRIBUTOR / VERTEILER
5	201.K301-500	3	
			KRYT / COVER / ABDECKUNG
6	201.K302-000	4	
			RAMENO / SHOULDER / SÄGERAHMEN
7	201.K303-000	7	
			STUL / TABLE / TISCH
8	201.K307-000	0	
			VALEC ZVEDACI / LIFTING CYLINDER / HEBEZYLLINDER
9	201.K314-000	5	
			UPINANI HORNI / TOP CLAM / SPANNVORRICHTUNG OBEN
10	30.K303-012 (1)	0	
			DRZAK / HOLDER / HALTER
11	30.K303-036 (1)	0	
			KOSTKA / CUBE / WÜRFEL
12	31.K399-101	1	
			STITEK / LABEL / SCHILD
13	90.001.25.008 (1)	0	
			SROUB IMBUS CERNENY / ALLEN HEAD BOLT / IMBUSSCHRAUBE
14	91.173.039 (1)	0	
			ZAMEK / LOCK / SCHLOSS
15	91.173.040 (3)	0	
			SPINAC KONCOVY / END SWITCH / ENDSCHALTER
16	99.900.039	0	
			SAMOLEPKA / STICKER / AUFKLEBER
17	99.900.040	0	
			SAMOLEPKA / STICKER / AUFKLEBER
18	99.900.046	0	
			SAMOLEPKA / STICKER / AUFKLEBER
19	99.900.047	0	
			SAMOLEPKA / STICKER / AUFKLEBER
20	99.900.048	0	
			SAMOLEPKA / STICKER / AUFKLEBER
21	99.900.049	0	
			SAMOLEPKA / STICKER / AUFKLEBER
22	99.900.066	0	
			SAMOLEPKA / STICKER / AUFKLEBER
23	99.901.009	0	
			SAMOLEPKA / STICKER / AUFKLEBER
			NEVKLADAT RUCE
			AL500

1. PRIDANY SAMOLEPKY 99.900.066, 99.900.039, 99.900.040, ZAMEK 91.173.039, SPINAC KONCOVY 91.173.040, DRZAK 30.K303-012, KOSTKA 30.K303-036, SROUB M5x12 (90.001.25.008), 259/ZM257 29.9.2010 SLEZACKOVA
2. ZRUS. ROZVADEC 201.K101-220 A NAHR. 201.K301-220. 322/ZM341 SLEZACKOVA 16.12.2010
3. PRIDAN I x ZAMEK 91.173.040. 151/ZM190 18.7.2011 SLEZACKOVA

6.3. Rameno / Sägerahmen / Saw arm - 1

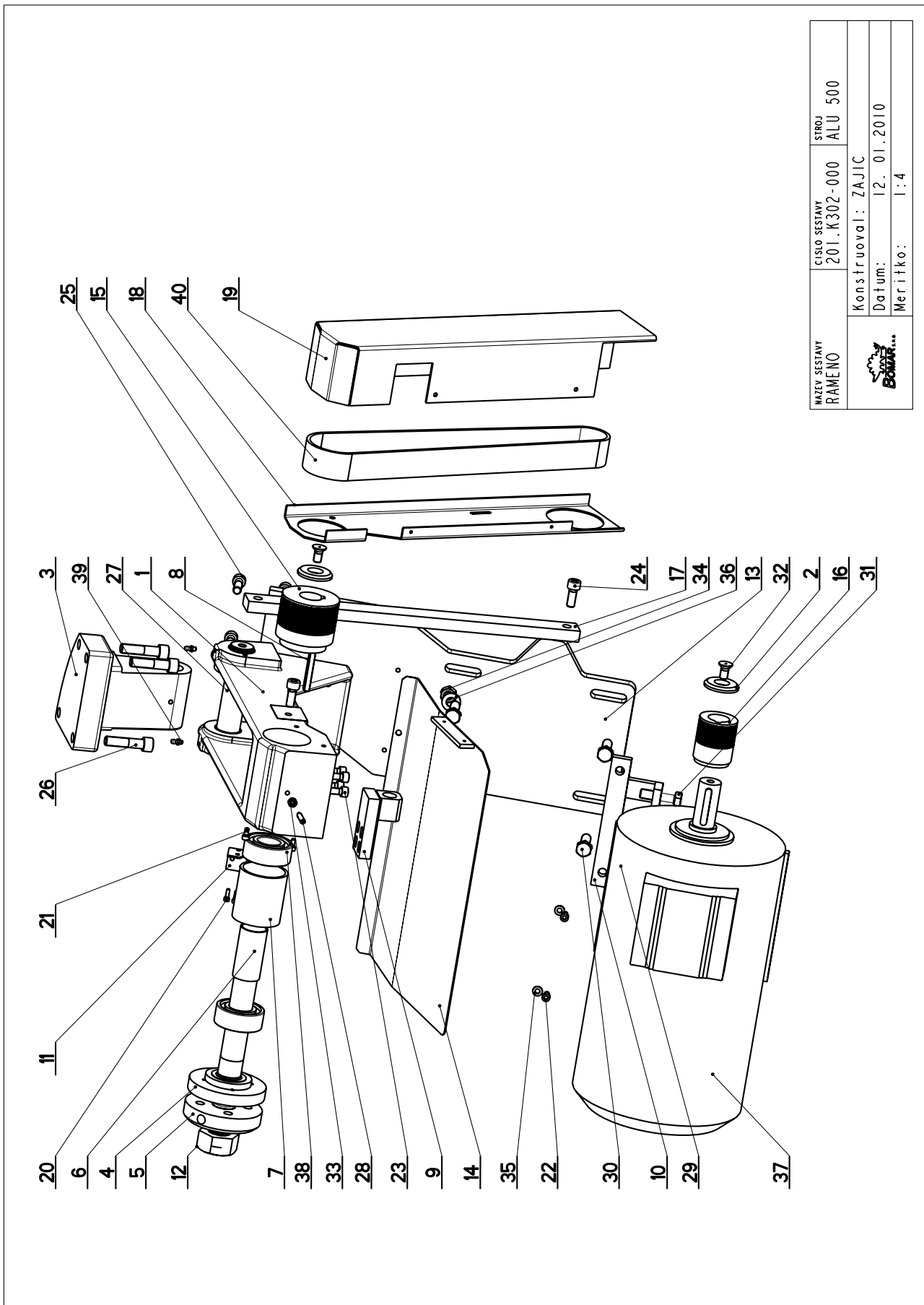

NAZEV SESTAVY RAMENO	CÍSLO SESTAVY 201.K302-000	STROJ ALU 500
Konstruoval: ZAJIC		
Datum: 12. 01.2010		
Meritko: 1:4		

6.4. Kusovník / Stückliste / Piece list – Rameno / Sägerahmen / Saw arm - 1

Cisto Sestavy 201.K302-000		Mozes sestavy RAMENO/SHOULDER/SÄGERAHMEN	
Poz.	Objednací číslo	Ver.	Ver.
1	201.K302-050	0	
2	30.1704-008	0	
3	30.K102-001	2	
4	30.K102-004	4	
5	30.K102-005	2	
6	30.K102-006	1	
7	30.K102-007	1	
8	30.K102-009	0	
9	30.K102-010	3	
10	30.K102-020	2	
11	30.K102-022	1	
12	30.K102-028	0	
13	30.K302-003	1	
14	30.K302-012	0	
15	30.K302-017	1	
16	30.K302-018	1	
17	30.K302-021	0	
18	30.K302-023	0	
19	30.K302-024	1	
20	90.001.25.003	0	
21	90.001.25.007	0	
22	90.001.25.016	0	
23	90.001.25.033	0	
24	90.001.25.047	0	
25	90.001.25.049	0	
26	90.001.25.062	0	
27	90.002.20.023	0	
28	90.004.20.004	0	
29	90.005.55.025	0	
30	90.005.55.034	0	
31	90.005.55.035	0	
32	90.011.27.008	0	
33	90.100.55.004	0	
34	90.100.55.007	0	
35	90.150.50.004	0	
36	90.150.50.007	0	

Mozes položky	Rozmer	Rs
KONZOLA / CONSOLE / KONSOLE		1
PODLOŽKA / WASHER / UMTERLEGSCHIBE	ø 45	2
KONZOLA / CONSOLE / KONSOLE	ODLITEK	1
HRIDEL / SHAFT / WELLE	ø 100	1
KOTOUČ / DISC / SCHEIBE	TYC 100	1
DISTANČ / DISTANCE / DISTANZ	TR 35x2	1
DISTANČ / DISTANCE / DISTANZ	TR 65x5	1
PERO / SPRING / FEDER	8x7	1
DRŽAK / HOLDER / HALTER		1
MAPÍKANI / TENSIONING / SPANNUNG		1
DRŽAK / HOLDER / HALTER	P2 x 25	1
MATICE / NUT / MUTTER	TYC 6HR 46	1
DRŽAK / HOLDER / HALTER		1
BRÝT / COVER / ABDECKUNG		1
BEHEMICE / PULLEY / RIEMENSCHIBE	TYC 75	1
BEHEMICE / PULLEY / RIEMENSCHIBE	TYC 50	1
VÝZTUHA / REINFORCEMENT / VERSTÄRFUNG	HR 30x15	1
BRÝT REHENE / BELT COVER / RIEMENABDECKUNG	P2 - 120	1
BRÝT REHENE / BELT COVER / RIEMENABDECKUNG	P 2 x 250	1
SROUB IMBUS / ALLEN HEAD BOLT / IMBUSSCHRAUBE	M6x12	2
SROUB IMBUS / ALLEN HEAD BOLT / IMBUSSCHRAUBE	M6x10	2
SROUB IMBUS / ALLEN HEAD BOLT / IMBUSSCHRAUBE	M6x12	2
SROUB IMBUS / ALLEN HEAD BOLT / IMBUSSCHRAUBE	8x25	4
SROUB IMBUS / ALLEN HEAD BOLT / IMBUSSCHRAUBE	M10x25	2
SROUB IMBUS / ALLEN HEAD BOLT / IMBUSSCHRAUBE	M10x35	4
SROUB IMBUS / ALLEN HEAD BOLT / IMBUSSCHRAUBE	M12x50	4
SROUB STAVEČI / ADJUSTMENT BOLT / STELLSCHRAUBE	SROUB M6x10	1
SROUB STAVEČI / ADJUSTMENT BOLT / STELLSCHRAUBE	SROUB M6x30	1
SROUB 6HRANNÝ / 6 SIDED BOLT / SECHSSEITIGSCHRAUBE	SROUB M10x30	1
SROUB 6HRANNÝ / 6 SIDED BOLT / SECHSSEITIGSCHRAUBE	SROUB M12x40	4
SROUB 6HRANNÝ / 6 SIDED BOLT / SECHSSEITIGSCHRAUBE	SROUB M12x45	1
SROUB ZAPUSTENÝ / COUNTERSINK BOLT / SEINWSCHRAUBE	SROUB M10x20	2
MATICE / NUT / MUTTER	MATICE - M6	1
MATICE / NUT / MUTTER	MATICE - M12	2
PODLOŽKA / WASHER / UMTERLEGSCHIBE	PODLOŽKA 6,4	2
PODLOŽKA / WASHER / UMTERLEGSCHIBE	PODLOŽKA 13	2

6.5. Rameno / Sägerahmen / Saw arm - 2

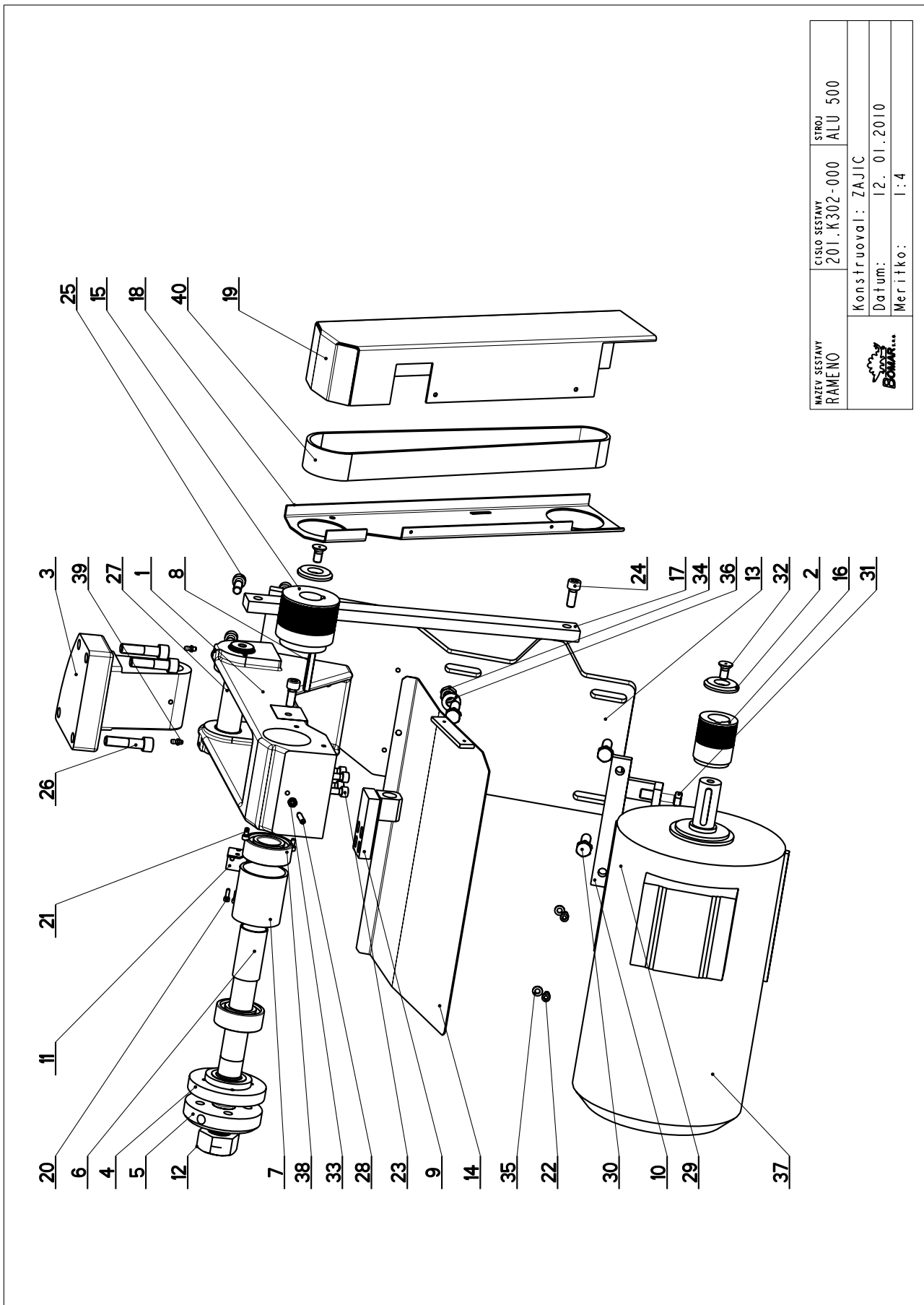

6.6. Kusovník / Stückliste / Piece list –
Rameno / Sägerahmen / Saw arm- 2

Cisto Sestavy 201.K302-000		Ver. 4	Název sestavy RAMENO/SHOULDER/SÄGERAHMEN		
Poz.	Objednávací číslo	Ver.	Název položky	Rozměr	Ks
37	91.001.054	0	ELEKTROMOTOR / ELECTRIC MOTOR / ELEKTROMOTOR	4 kW	1
38	95.001.039	0	LOŽISKO / BEARING / LAGER	5206-2RS	2
39	95.860.001	0	HLAVICE MAZACÍ / HEAD / KOPF	MMS	2
40	99.023.009	0	REMETNÍK DRÁŽKOVÝ / GROOVED BELT / KEILRIEMEN	18PJ	1

6.7. Podstavec / Untersatz / Base

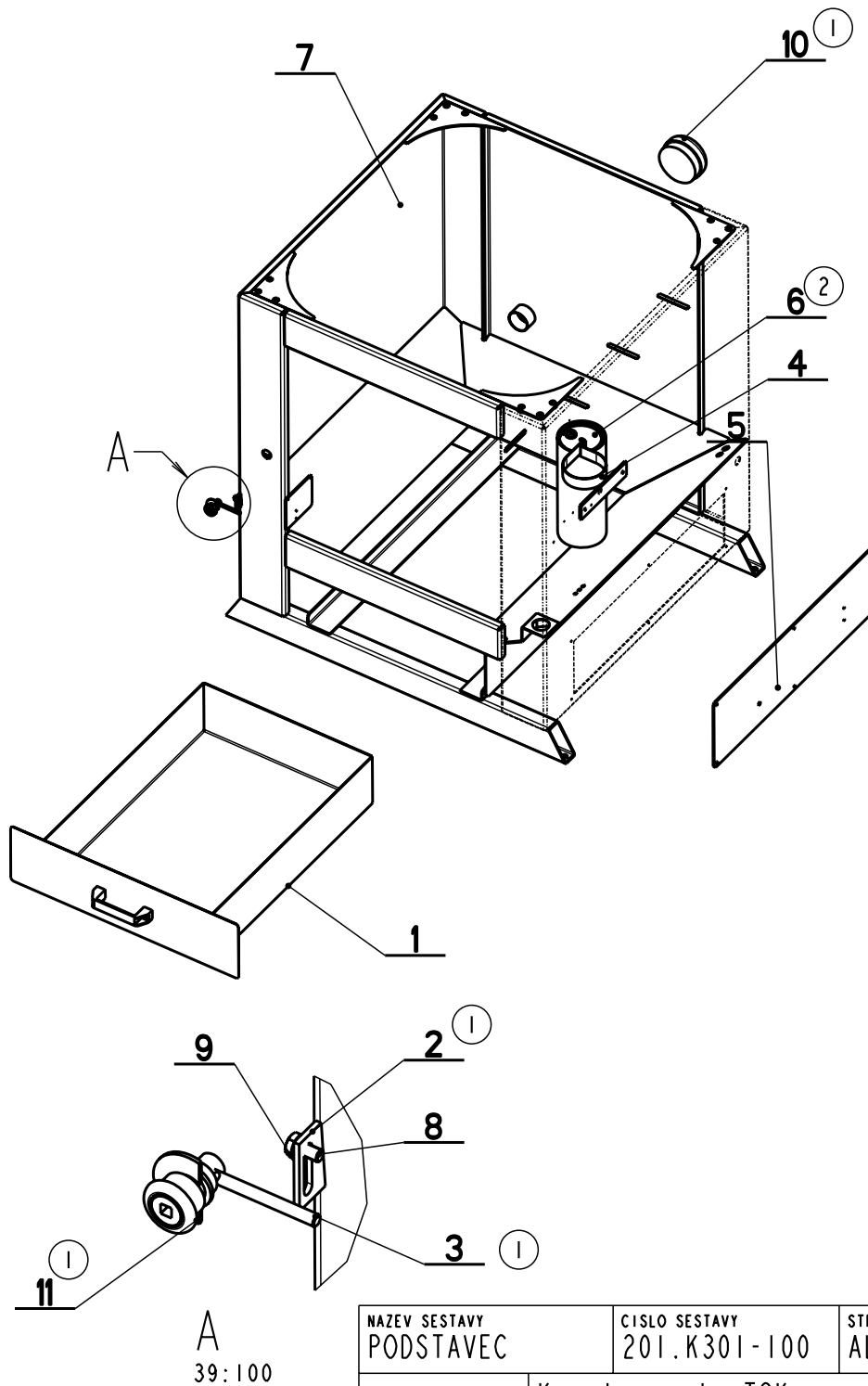

A
39:100

NAZEV SESTAVY PODSTAVEC	CISLO SESTAVY 201.K301-100	STROJ AL500
	Konstruoval: TOK	
	Datum: 15. 02.2010	
	Meritko: 2:25	

6.8. Kusovník / Stückliste / Piece list –
Podstavec / Untersatz / Base

Cislo Sestavy 201.K301-100		Ver. 1		Název sestavy PODSTAVEC / BASE / UNTERSATZ	
Poz.	Objednací číslo	Ver.	Název položky	Rozměr	Ks
1	201.K101-145	0	VANA / TANK / WANNE		1
2	30.K100-111 (1)	0	DRŽAK / HOLDER / HALTER	P 3-22	1
3	30.K101-154 (1)	0	TYC / POLE / STANGE	D 6	1
4	30.K103-023	0	DRŽAK / HOLDER / HALTER	Pl. 5x30	1
5	30.K107-112	1	KRYT / COVER / ABDECKUNG	P 3x 190	1
6	30.K107-300 (2)	1	VALEC / CONTAINER / BEHÄLTER		1
7	30.K301-101	1	PODSTAVEC / BASE / UNTERSATZ		1
8	90.005.55.006	0	SROUB 6HRANNY / 6 SIDED BOLT / SECHSKANTSCHRAUBE	SROUB M6X12	1
9	90.150.50.004	0	PODLOŽKA / WASHER / UNTERLEGSCHIBE	PODLOŽKA 6,4	1
10	94.100.020 (1)	0	ZATKA / PLUG / STOPFEN		1
11	99.104.004 (1)	0	ZAMEK ROZVADECOVY / DISTRIBUTOR LOCK / VERTEILERSCHLOSS	LK3	1

1. ZRUSEN ZAMEK 91.990.001 A NAHRZEN 99.104.004, PRIDANY SOUCASTI 30.K101-154, 30.K100-111 A 94.100.020 026/ZM038
9.2.2010 TOK

2. ZRUSENA SOUCAST 201.K107-300 A NAHR.30.K107-300. 048/ZMI48 24.5.2010 SLEZACKOVA

Cislo Sestavy/Number of assembly/Nummer der Baugruppe; Verze (Ver.)/Version/Version; Název sestavy/Assembly title/Name der Baugruppe; Pozice (Poz.)/Position/Position;
Objednací číslo/Purchase order number/Bestellnummer; Název položky/Volume title/Name der Position; Rozměr/Stock size/Abmessung

6.9. Kryt / Cover / Abdeckung

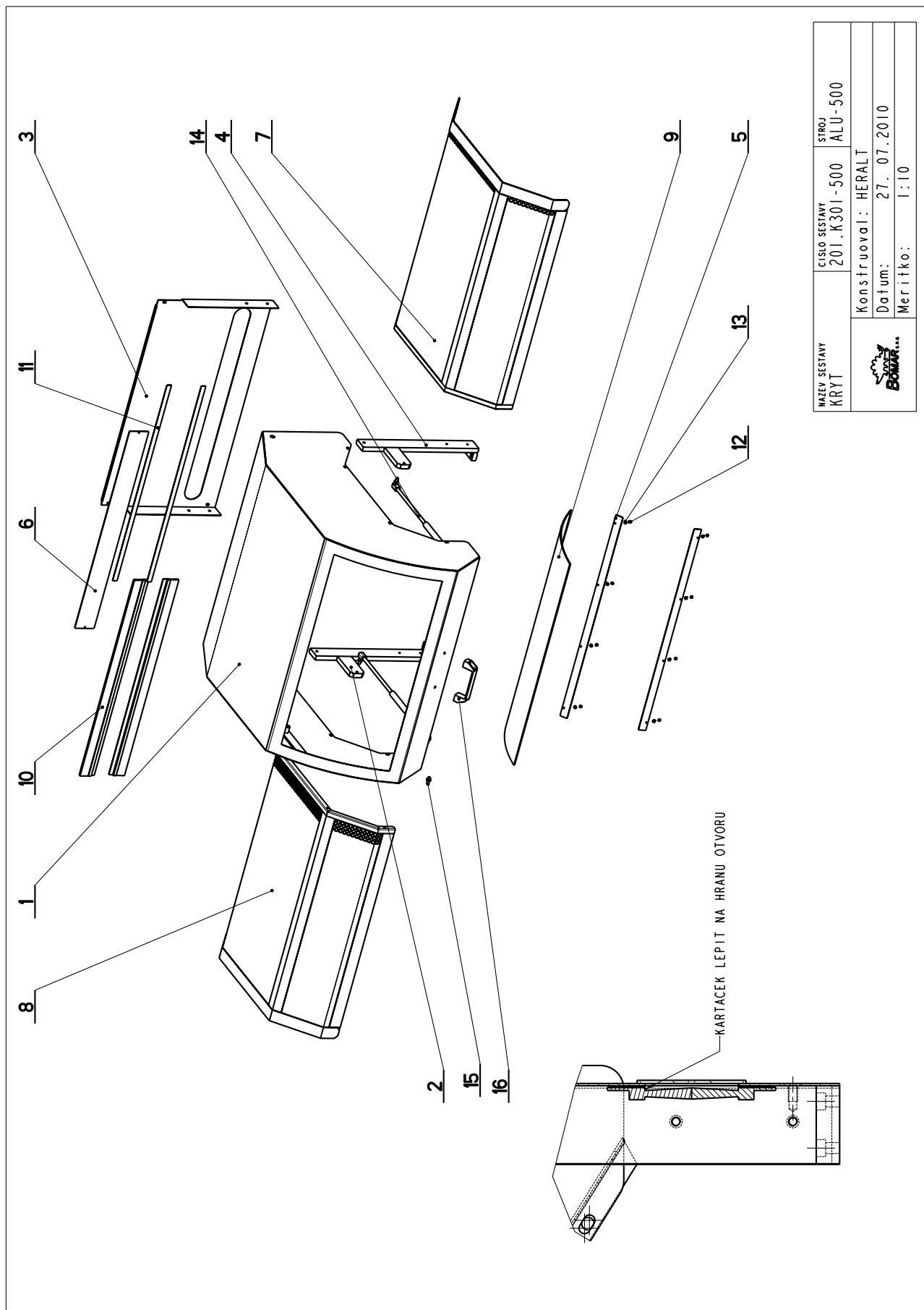

6.10. Kusovník / Stückliste / Piece list – Kryt / Cover / Abdeckung

Císlo Sestavy 201.K301-500		Ver. 2		Název sestavy KRYT/COVER/ABDECKUNG	
Poz.	Objednáací číslo	Ver.	Název položky	Rozměr	Ks
1	30.K301-501	0	KRYT / COVER / ABDECKUNG		1
2	30.K301-502	0	DRŽAK / HOLDER / HALTER		1
3	30.K301-503	1	KRYT / COVER / ABDECKUNG	P 2x426x867	1
4	30.K301-504	0	DRŽAK / HOLDER / HALTER		1
5	30.K301-506	0	LISTA / TRIM / LEISTE	P2 x 25	2
6	30.K301-512	1	KRYT / COVER / ABDECKUNG	P 2x70x730	1
7	30.K301-513		KRYT / /		1
8	30.K301-514		KRYT / COVER / ABDECKUNG		1
9	31.K301-505	0	SKLO ORGANICKE / PLEXIGLASS / PLEXIGLAS	3x395.5	1
10	49.250.004	0	KARTAC / BRUSH / BÜRSTE	FBL6000-K5	2
11	61.360.002	0	PAS / BELT / BAND	16mm	2
12	90.100.55.002	0	MATICE DIN 934 / NUT / MUTTER	MATICE - M4	8
13	90.150.50.002	0	PODLOŽKA / WASHER / UNTERLEGSCHIEBE	PODLOŽKA 4.3	8
14	93.004.004	0	VZPERA PLYNOVA / GAS PROP / GASDRUCKFEDER	D18-530	2
15	93.004.005	0	CEP / LUG / BOLZEN	PRO PLYN. VZPERY	1
16	94.012.001	0	RUKOJET / HANDLE / GRIFF		1

1. ZM. PRIDANY POZ. 49.250.004, 61.360.002, 30.K301-512, POZ. 94.012.001 NAHRADILA POZ. 30.K101-509. 5.11.04 VRSECKY
 POZ. 49.250.004 LEPIT OBOUSTRANNOU LEPICI PASKOU POZ. 61.360.002 NA ODMASTENY POVRCH

2. PRIDANA POLOZKA 93.004.005 7.4.2006 RYSAVY

6.11. Stůl / Table / Tisch

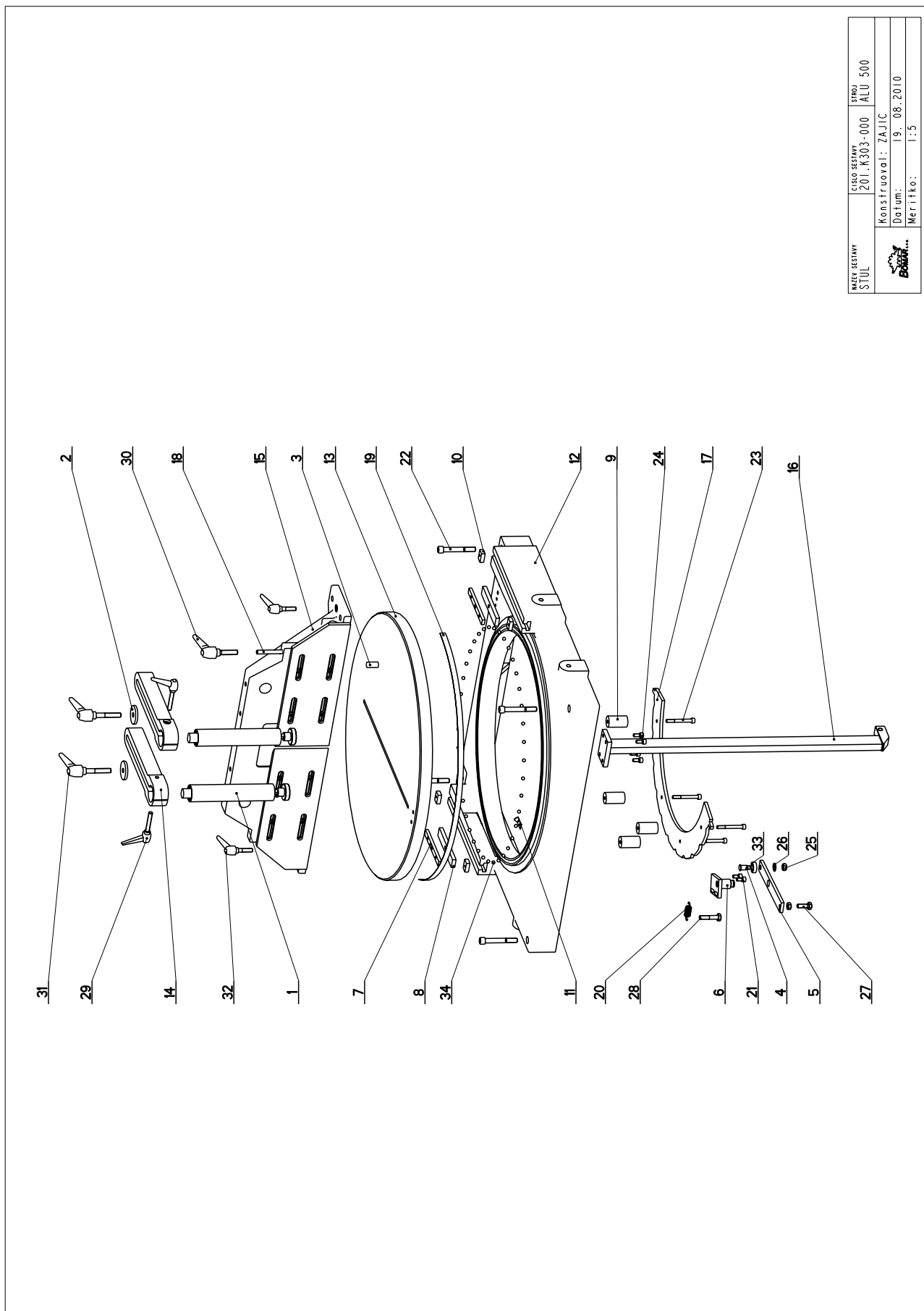



INEX SESTAV STUL	CISCO SESTAV 201.K303-000	STROJ ALU 500
Konstruoval: ZAJIC		Datum: 19. 08. 2010
Meritko: 1:5		

6.12. Kusovník / Stückliste / Piece list – Stůl / Table / Tisch

Císlo Sestavy 201.K303-000		Nozov sestavy STUL / TABLE / TISCH	
Ver. 6		Ver.	
Poz.	Objednací číslo	Název položky	Rozměr
1	201.K107-400	VALEC UPINACÍ / FIXING CYLINDER / SPANNZYLINDER	
2	30.0502-603	PODLOŽKA / WASHER / UNTERLEGSCHIEBE	d50
3	30.0509-606	VALEČEK / CYLINDER / ROLLE	d15
4	30.0802-011	CEP / LUG / BOLZEN	d16
5	30.0802-013	PAKA / LEVER / HEBEL	HR 30 x 8
6	30.3509-013	CEP / LUG / BOLZEN	
7	30.K103-008	LISTA VODICI / LEAD TRIM / FÜHRUNGSLEISTE	HR 15x8
8	30.K103-009	LISTA VODICI / LEAD TRIM / FÜHRUNGSLEISTE	HR 25x10
9	30.K103-016	DISTANČ / DISTANCE / DISTANZ	d30
10	30.K103-017	DORAZ / STOP PIECE / ANSCHLAG	HR 20 x 10
11	30.K103-024	UKAZATEL / INDICATOR / ZEIGER	P1 1x15
12	30.K303-001	STUL / TABLE / TISCH	ODLITEK
13	30.K303-002	STUL / TABLE / TISCH	ODLITEK
14	30.K303-004	DRŽAK / HOLDER / HALTER	ODLITEK
15	30.K303-005	CELIST PEVNA / SOLID JAW / FESTE BACKE	SESTAVA
16	30.K303-013	DRŽAK / HOLDER / HALTER	
17	30.K303-015	SEGMENT / SEGMENT / SEGMENT	P8 - 280
18	30.K303-018	TYC / POLE / STANGE	d10
19	30.K303-022	MERITKO / MEASURE / SKALA	P0.5x15
20	31.K303-021	PRUŽINA / SPRING / FEDER	2.0x16x53x13.5
21	90.001.25.031	SROUB IMBUS CERNÝ / ALLEN HEAD BOLT / IMBUSSCHRAUBE	8x16
22	90.001.25.072	SROUB IMBUS / ALLEN HEAD BOLT / IMBUSSCHRAUBE	M12x90
23	90.001.25.095	SROUB IMBUS / ALLEN HEAD BOLT / IMBUSSCHRAUBE	M8x70
24	90.001.25.105	SROUB IMBUS / ALLEN HEAD BOLT / IMBUSSCHRAUBE	M8x18
25	90.100.55.006	MATICE / NUT / MÜTTER	MATICE - M10
26	90.150.50.006	PODLOŽKA / WASHER / UNTERLEGSCHIEBE	PODLOŽKA 10,5
27	90.401.02.002	SROUB 6HRANNÝ / 6 SIDED BOLT / SECHSKANTSCHRAUBE	SROUB M10x30
28	90.401.02.002	SROUB 6HRANNÝ / 6 SIDED BOLT / SECHSKANTSCHRAUBE	SROUB M10x50
29	94.008.006	PAKA UPINACÍ / ATTACHMENT LEVER / SPANNHEBEL	M10
30	94.008.009	PAKA UPINACÍ / ATTACHMENT LEVER / SPANNHEBEL	M12
31	94.008.012	PAKA UPINACÍ / ATTACHMENT LEVER / SPANNHEBEL	M12x70
32	94.008.013	PAKA UPINACÍ / ATTACHMENT LEVER / SPANNHEBEL	M10
33	95.001.005	LOŽISKO / BEARING / LAGER	6001 ZRS
34	95.691.006	KOLEČKO / WHEEL / ROLLE	RB 8

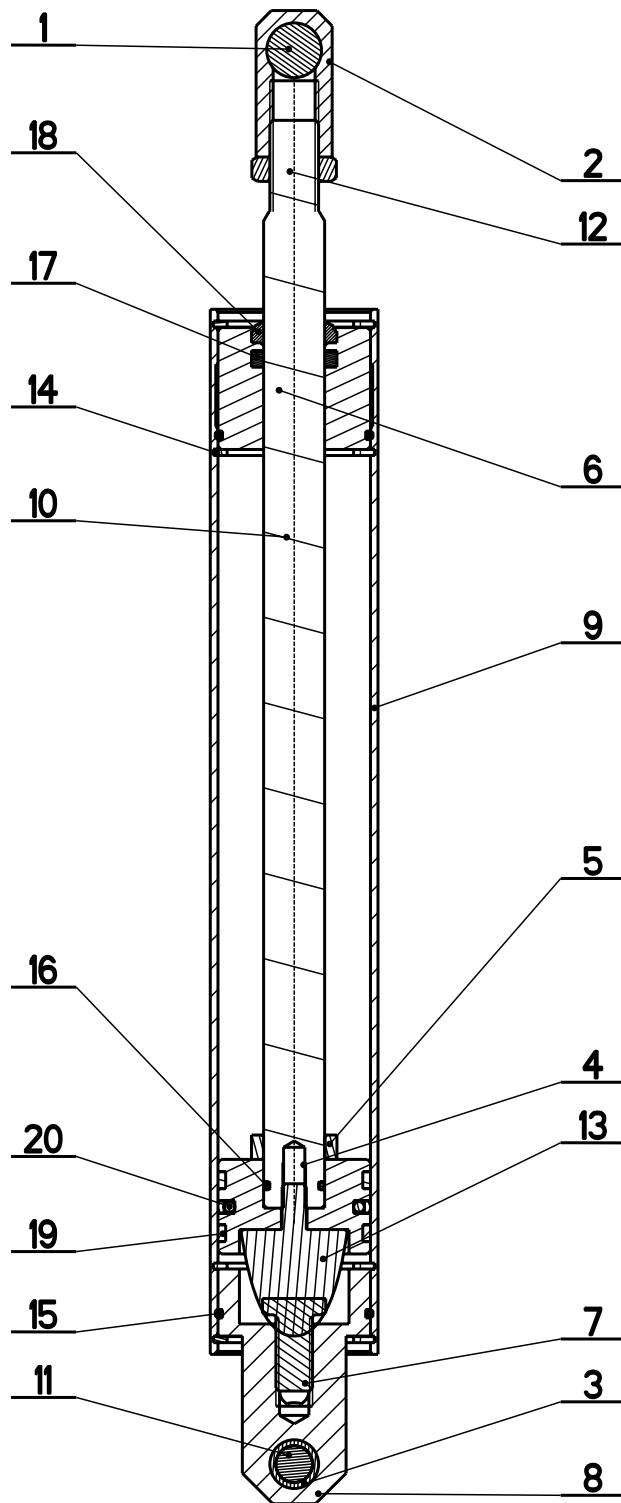
6.13. Válec zvedací / Hebezyylinder / Lifting cylinder



NAZEV SESTAVY VALEC ZVEDACI	CISLO SESTAVY 201.K307-000	STROJ ALU-500
	Konstruoval: ZAJIC	
	Datum: 11. 01.2010	
	Meritko: 1:2	

6.14. Kusovník / Stückliste / Piece list – Válec zvedací / Hebezylinder / Lifting cylinder

Cislo sestavy 201.K307-000		Ver. 0	Název sestavy VALEC ZVEDACI/LIFTING CYLINDER/HEBEZYLINDER		
Poz.	Objednací číslo	Ver.	Název položky	Rozměr	Ks
1	30.0514.904	0	CEP / LUG / BOLZEN	d 18	1
2	30.0807.006	0	DRZAK / HOLDER / HALTER	TYC 25x25	1
3	30.K107.003	2	POUZDRO / SLEEVE / BÜCHSE	d 18	1
4	30.K107.004	1	PIST / PISTON / KOLBEN	TYC 55	1
5	30.K107.005	0	DISTANC / DISTANCE / DISTANZ	TR 28x4	1
6	30.K107.008	3	VÍKO / COVER / DECKEL	d 55	1
7	30.K107.009	1	SROUB 6HRANNÝ / 6 SIDED BOLT / SECHSKANTSCHRAUBE	SROUB M12X25	1
8	30.K107.011	2	VÍKO / COVER / DECKEL	d 50	1
9	30.K307.001	0	VALEC / ROLLER / ZYLINDER	TR 55/50H8	1
10	30.K307.002	0	PISTNICE / PISTON ROD / KOLBENSTANGE	d20	1
11	90.001.25.062	0	SROUB IMBUS / ALLEN HEAD BOLT / IMBUSSCHRAUBE	M12X50	1
12	90.101.55.003	0	MATICE / NUT / MUTTER	MATICE M16	1
13	94.700.001	0	SILENTBLOK / SILENT BLOCK / SCHWINGUNGSDÄMPFER		1
14	95.801.018	0	KROUZEK POJIST.VNITR / INSIDE SAFETY RING / SICHERUNGSRING INNEN	POJISTINY KROUZEK 50	4
15	96.001.013	0	O-KROUZEK STATIC / STATIC O RING / O-RING STATISCH	45X2	2
16	96.002.007	0	O-KROUZEK DYNAMIC / DYNAMIC O RING / O-RING DYNAMISCH	16X2	1
17	96.041.002	0	TESNĚNÍ / SEALING / DICHTUNG	601-20x28x5	1
18	96.060.002	0	KROUZEK STIRACI / SCRAPER RING / ABSTREIFRING	KROUZEK STIRACI 20	1
19	96.084.001	0	KROUZEK VODICI / LEAD RING / FÜHRUNGSRING		2
20	96.900.001	0	TESNĚNÍ KOMBINOVANÉ / COMBINATION SEALING / KOMBIDICHTUNG		1

6.15. Vana / Wanne / Tank

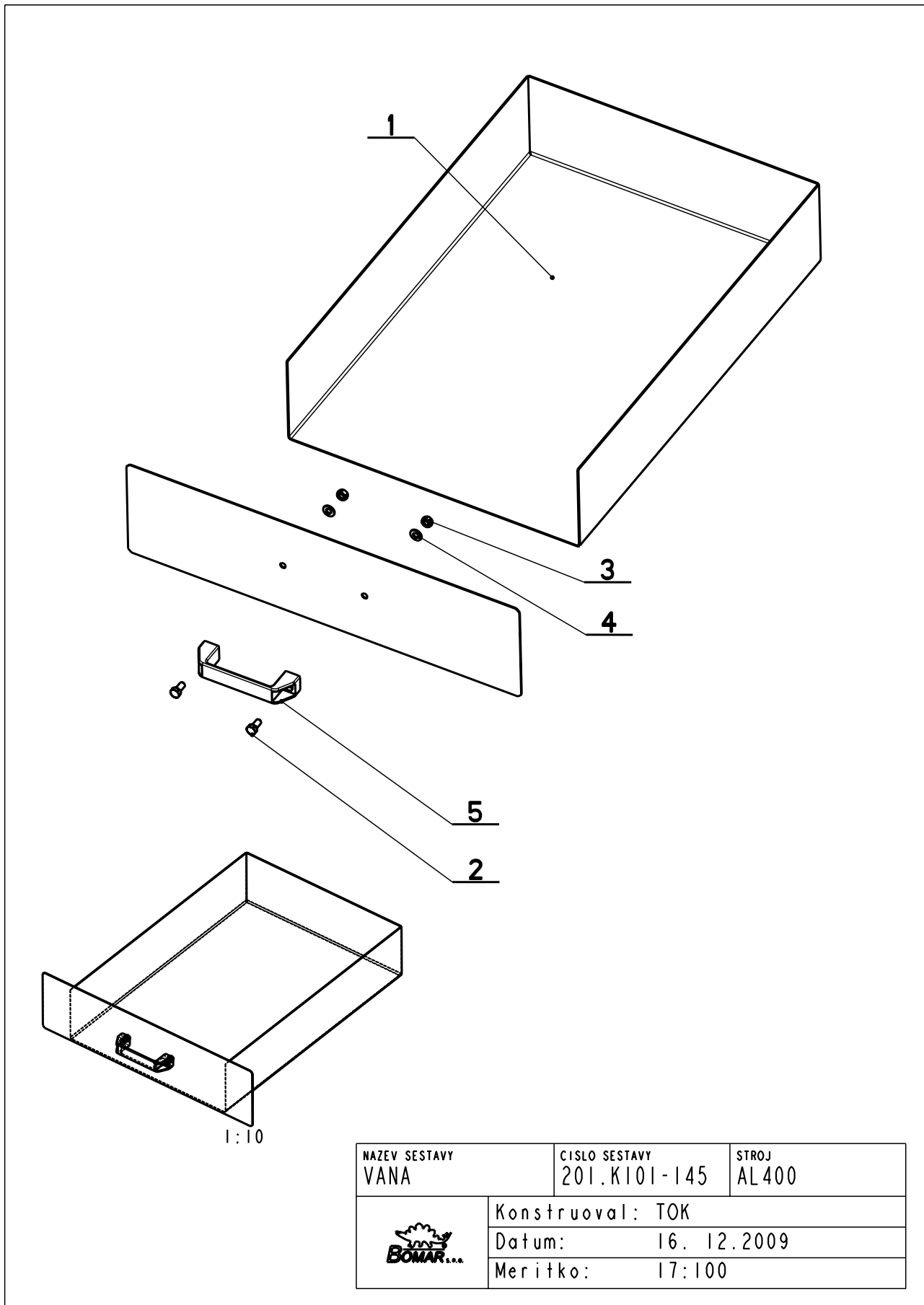

NAZEV SESTAVY VANA	CISLO SESTAVY 201.K101-145	STROJ AL400
	Konstruoval: TOK	
	Datum: 16. 12.2009	
	Meritko: 17:100	

6.16. Kusovník / Stückliste / Piece list – Vana / Wanne / Tank

Cislo Sestavy 201.K101-145		Ver. 0		Název sestavy VANA/TANK/WANNE	
Poz.	Objednáací číslo	Ver.	Název položky	Rozměr	Ks
1	30.K101-144	0	VANA / TANK / WANNE		1
2	90.005.55.014	0	SROUB 6HRANNÝ / 6 SIDED BOLT / SECHSKANTSCHRAUBE	SROUB M8X16	2
3	90.100.55.005	0	MATICE / NUT / MUTTER	MATICE - M8	2
4	90.150.50.005	0	PODLOZKA / WASHER / UMTERLEGSCHIBE	PODLOZKA 8,4	2
5	94.012.001	0	RUKOJET / HANDLE / GRIF		1

Cislo Sestavy/Number of assembly/Nummer der Baugruppe; Verze (Ver.)/Version/Version; Název sestavy/Assembly title/Name der Baugruppe; Pozice (Poz.)/Position/Position;
Objednáací číslo/Purchase order number/Bestellnummer; Název položky/Volume title/Name der Position; Rozměr/Stock size/Abmessung

6.17. Rozvaděč / Verteiler / Distributor

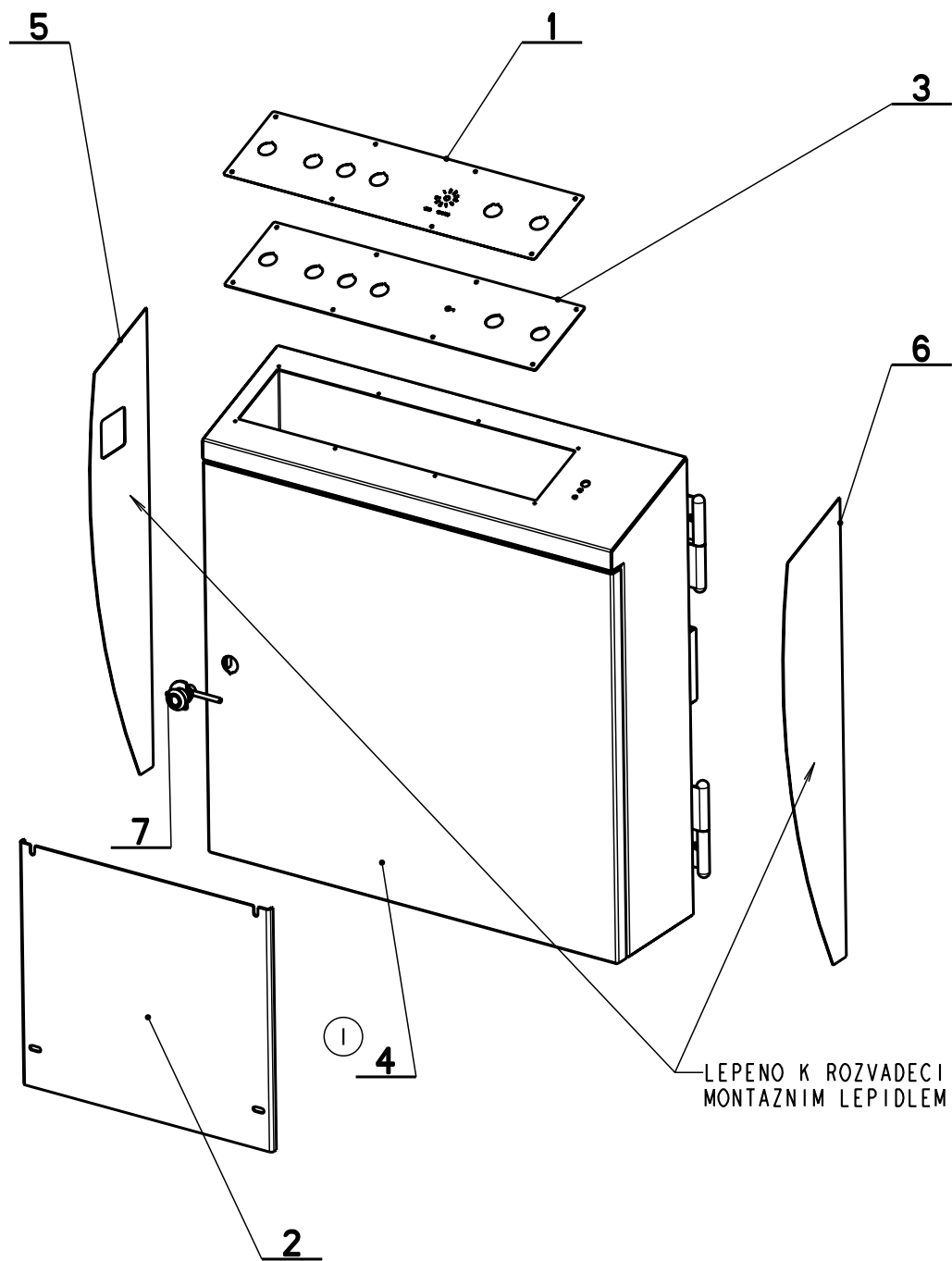

NAZEV SESTAVY ROZVADEC	CISLO SESTAVY 201.K101-220	STROJ AL400
	Konstruoval: TOK	
	Datum: 05. 02.2010	
	Meritko: 7:50	

6.18. Kusovník / Stückliste / Piece list – Rozvaděč / Verteiler / Distributor

Cislo Sestavy 201.K101-220		Ver. 2		Název sestavy ROZVADEC/DISTRIBUTOR/VERTEILER	
Poz.	Objednací číslo	Ver.	Název položky	Rozměr	Ks
1	30.K101-206	3	OVLADACÍ PANEL / CONTROL PANEL / BEDIENPULT	P 0.5 x 123	1
2	30.K101-207	0	DESKA ELEKTRO / ELECTRIC BOARD / PLATINE	P2x340	1
3	30.K101-212	2	PANEL / PANEL / PANEL	P 1.5 x 123	1
4	30.K101-221	1	ROZVADEC / DISTRIBUTOR / VERTEILER		1
5	30.K101-231	0	PLECH / PLATE / BLECH	P 1-134	1
6	81.K101-230 (1)	0	PLECH / STICKER / AUFKLEBER	P 1-134	1
7	91.990.001	0	ZAMEK ROZVADECOVY / DISTRIBUTOR LOCK / VERTEILERSCHLOSS		1

1. ZRUS. ROZVADEC 31.K101-222 A NAHR. 30.K101-221. 021/ZM032 5.2.2010 SLEZACKOVA

2. ZRUSEN PANT 30.K101-209, 30.K101-208. 090/ZM162 31.5.2010 SLEZACKOVA

Cislo Sestavy/Number of assembly/Nummer der Baugruppe; Verze (Ver.)/Version/Version; Název sestavy/Assembly title/Name der Baugruppe; Pozice (Poz.)/Position/Position;
Objednací číslo/Purchase order number/Bestellnummer; Název položky/Volume title/Name der Position; Rozměr/Stock size/Abmessung

6.19. Upínání horní / Spannvorrichtung oben / Top clamping

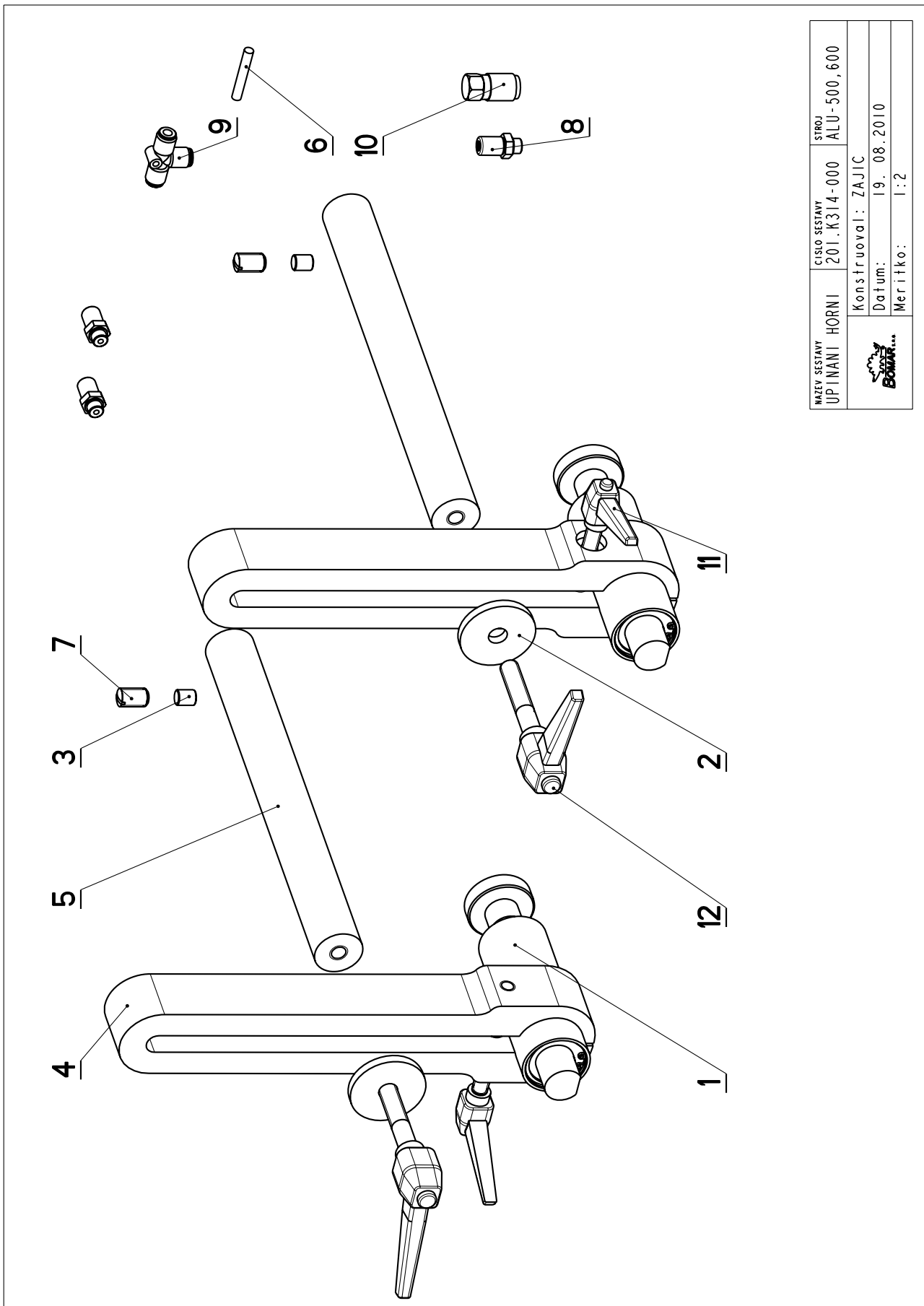



6.20. Kusovník / Stückliste / Piece list – Upínání horní / Spannvorrichtung oben / Top clamping

Cislo Sestavy 201.K314-000		Ver. 4		Název sestavy UPINANI HORNÍ / TOP CLAM/SPANNVORRICHTUNG OBEN	
Poz.	Objednací číslo	Ver.	Název položky	Rozměr	Ks
1	201.K107-500	0	VALEC UPINACÍ / FIXING CYLINDER / SPANNZYLINDER		2
2	30.0502-603	1	PODLOŽKA / WASHER / UNTERLEGSCHLEIBE	ø50	2
3	30.K103-022	0	VALECEK / CYLINDER / ROLLE	ø 10	2
4	30.K303-004	0	DRŽÁK / HOLDER / HALTER	ODLITEK	2
5	30.K303-019	0	TYC / POLE / STANGE	ø 32	2
6	43.001.008	0	HADICE / HOSE / SCHLAUCH	PU6	1
7	90.002.2D.018	0	SROUB STAVEČÍ / ADJUSTMENT BOLT / STELLSCHRAUBE	SROUB M12X20	2
8	93.005.001	0	SROUBENÍ PRÍME / DIRECT BOLTING / GERADE VERSCHRAUBUNG	G 1/8-6/4	3
9	93.011.002	0	PROPOJKA T / CONNECTION T / VERBINDUNGSSTÜCK T	6	1
10	93.023.001	0	SPOJKA / JOINT / KUPPLUNG	182-1/8"	1
11	94.008.006	0	PAKA UPINACÍ / ATTACHMENT LEVER / SPANNHEBEL	M10	2
12	94.008.012	0	PAKA UPINACÍ / ATTACHMENT LEVER / SPANNHEBEL	M12x70	2

Cislo Sestavy/Number of assembly/Nummer der Baugruppe; Verze (Ver.)/Version/Version; Název sestavy/Assembly title/Name der Baugruppe; Pozice (Poz.)/Position/Position;
Objednací číslo/Purchase order number/Bestellnummer; Název položky/Volume title/Name der Position; Rozměr/Stock size/Abmessung

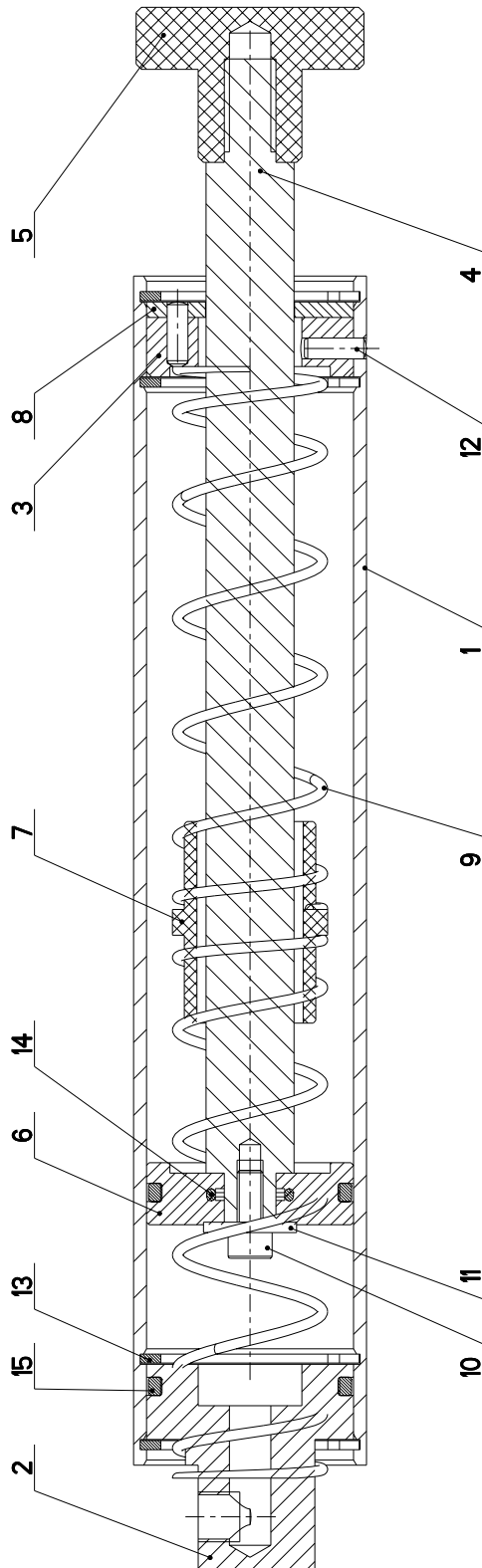
6.21. Válec upínací / Spannzyylinder / Fixing cylinder 1



NAZEV SESTAVY VALEC UPINACI	CISLO SESTAVY 201.K107-100	STROJ ALU 400
		
Konstruoval: ZAJIC		
Datum: 07. 01. 2010		
Meritko: 6:5		

6.22. Kusovník / Stückliste / Piece list – Válec upínací / Spannzyylinder / Fixing cylinder 1

Císlo sestavy 201.K107-100		Název sestavy VALEC UPÍNAČÍ / FIXING CYLINDER / SPANNZYINDER		Ver. 0	Ks	
Poz.	Objednací číslo	Ver.	Název položky	Rožmer		
1	30.K107-101	0	VALEC UPÍNAČÍ / FIXING CYLINDER / SPANNZYINDER	TR 45/40H8	1	
2	30.K107-102	0	VIHO / COVER / DECKEL	d 45	1	
3	30.K107-103	1	VIHO / COVER / DECKEL	d 45	1	
4	30.K107-104	2	PISTNICE / PISTON ROD / KOLBENSTANGE	6H8-17	1	
5	30.K107-105	1	DORAZ / STOP PIECE / ANSCHLAG	d 50	1	
6	30.K107-106	1	PIST / PISTON / KOLBEN	d 45	1	
7	30.K107-109	0	KROUZEK VODÍČÍ / LEAD RING / FÜHRUNGSRING	d 30	1	
8	30.K107-111	0	KROUZEK VODÍČÍ / LEAD RING / FÜHRUNGSRING	d 40	1	
9	31.K107-107	0	PRUŽINA / SPRING / FEDER	2x30x105x15+2	2	
10	90.001.25.008	0	SPROUB IMBUS ČERNĚNÝ / ALLEN HEAD BOLT / IMBUSSCHRAUBE	M5X12	1	
11	90.151.50.006	0	PODLOŽKA VĚL.KOPL. / WASHER / UNTERLEGSCHIBE	PODLOŽKA 5	1	
12	90.303.0Z.013	0	KOLÍK PRUŽNÝ / PIN / BOLZEN	KOLÍK 4X12	2	
13	95.801.005	0	SEGR DÍRA / INSIDE SAFETY RING / SICHERUNGSRING INNEN	POJISTNÝ KROUZEK 40	4	
14	96.001.004	0	O-KROUZEK STATICKÝ / STATIC O RING / O-RING STATISCH	10X2	1	
15	96.002.017	0	O-KROUZEK DYNAMICKÝ / DYNAMIC O RING / O-RING DYNAMISCH	34X3	2	

6.23. Válec upínací / Spannzyylinder / Fixing cylinder 2

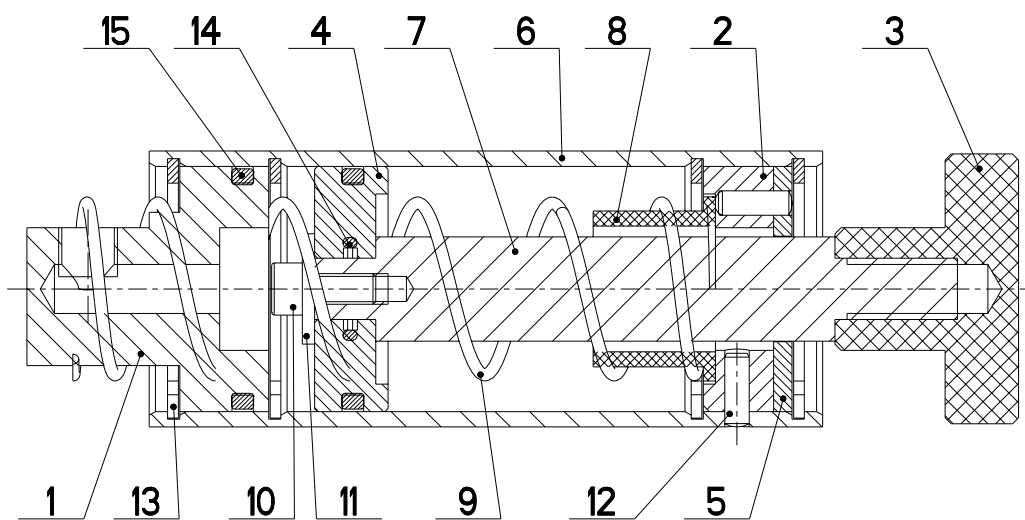

NAZEV SESTAVY VALEC UPINACI	CISLO SESTAVY 201.K107-200	STROJ ALU-400
	Konstruoval: ZAJIC	
	Datum: 11. 01.2010	
	Meritko: 1:1	

6.24. Kusovník / Stückliste / Piece list – Válec upínací / Spannzyylinder / Fixing cylinder 2

Císlo Sestavy 201..K107-200		Ver. 0		Název sestavy VALEC UPÍNAČÍ/FIXING CYLINDER/SPANNZYLINDER	
Poz.	Objednací číslo	Ver.	Název položky	Rožmer	Ks
1	30.K107-102	0	VÍKO / COVER / DECKEL	∅ 45	1
2	30.K107-103	1	VÍKO / COVER / DECKEL	∅ 45	1
3	30.K107-105	1	DORAZ / STOP PIECE / ANSCHLAG	∅ 50	1
4	30.K107-106	1	PIST / PISTON / KOLBEN	∅ 45	1
5	30.K107-111	0	KROUZEK VODÍČÍ / LEAD RING / FÜHRUNGSRING	∅ 40	1
6	30.K107-201	0	VALEC / ROLLER / ZYLINDER	TR 45/40H8	1
7	30.K107-204	0	PISTNICE / PISTON ROD / KOLBENSTANGE	6HR-17	1
8	30.K107-209	0	VEDENÍ / GUIDE / BACKENFÜHRUNG	∅30	1
9	31.K107-107	0	PRUŽINA / SPRING / FEDER	2×30x105x(5+2)	1
10	90.001.25.008	0	SROUB IMBUS ČERNÝ / ALLEN HEAD BOLT / IMBUSSCHRAUBE	M3X12	1
11	90.151.50.006	0	PODLOZKA / WASHER / UNTERLEGSCHIBE	PODLOZKA 5	1
12	90.303.02.013	0	KOLÍK / PIN / BOLZEN	KOLÍK 4X12	2
13	95.801.005	0	KROUZEK POJIST.VNITR / INSIDE SAFETY RING / SICHERUNGSRING INNEN	POJISTINY KROUZEK 40	4
14	96.001.004	0	O-KROUZEK STATIC / STATIC O RING / O-RING STATISCH	10X2	1
15	96.002.017	0	O-KROUZEK DYNAMIC / DYNAMIC O RING / O-RING DYNAMISCH	34X3	2

6.25. Válec / Zylinder / Cylinder

Cislo Sestavy 201.K107-300		Nazev sestavy VALEC/ROLLER/ZYLINDER			
Poz.	Objednaci cislo	Ver.	Nazev polozky	Rozmer	Ks
1	30.K107-301	5	VALEC / CONTAINER / BEHALTER		1
2	30.K107-302	2	VIKO / COVER / DECKEL	d 110	1
3	90.400.57.002	0	ZATKA / PLUG / STOPFEN	M16x1.5	1
4	95.801.031	0	KROUZEK POJIST.VNITR / INSIDE SAFETY RING / SICHERUNGSRING INNEN	POJISTNY KROUZEK 100	1
5	96.002.022	0	KROUZEK O DYNAMICKY / DYNAMIC O RING / O-RING DYNAMISCH	95x2	1
6	96.081.001	0	KROUZEK TESNICI / SEAL RING / DICHTUNGSRING	23x15x3	1

1. ZRUS. 1 x "O" KROUZEK 96.002.022, 1 x POJISTNY KROUZEK 95.801.031. 048/ZM148 24.5.2010 SLEZACKOVA

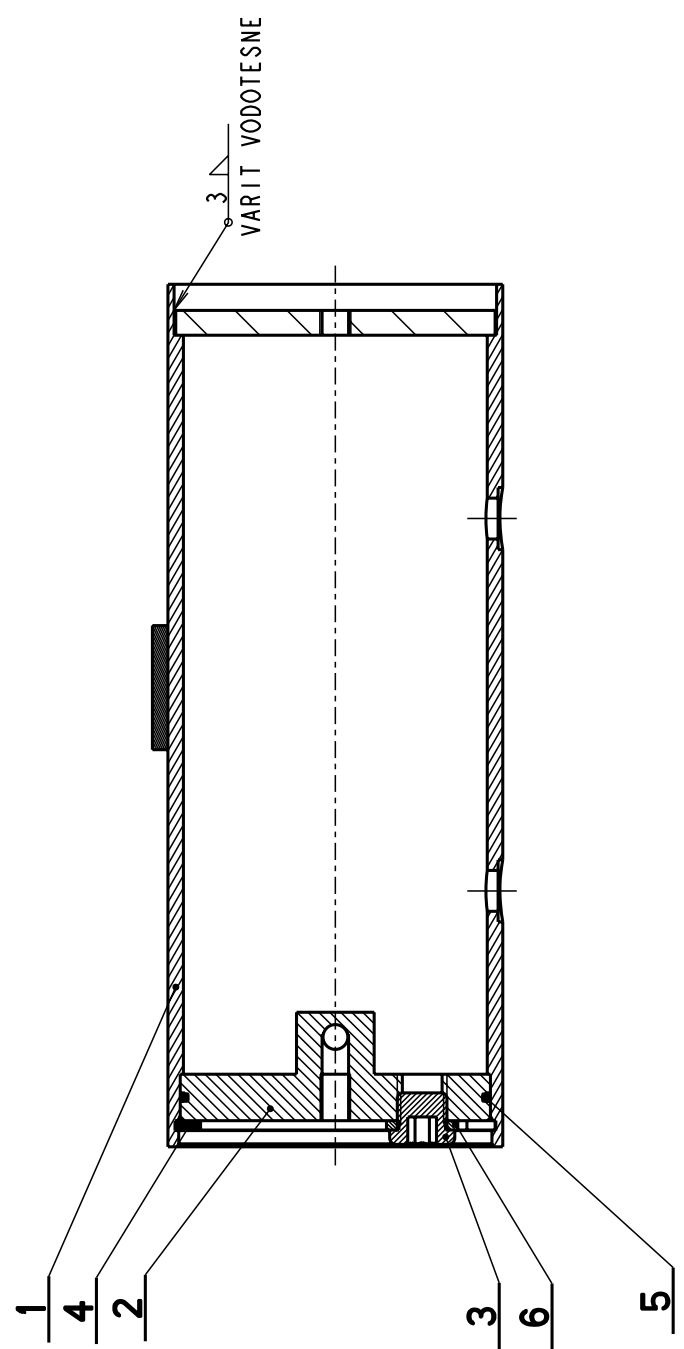

6.26. Konzola / Konsole / Console

Cislo Sestavy 201.K302-050		Ver. 0	Nazev sestavy KONZOLA/CONSOLE/KONSOLE		
Poz.	Objednaci cislo	Ver.	Nazev polozky	Rozmer	Ks
1	30.K302-002	4	KONZOLA / CONSOLE / KONSOLE	ODLITEK	1
2	30.K102-008	3	CEP / LUG / BOLZEN	d 32	1
3	30.K102-025	1	POUZDRO / SLEEVE / BÜCHSE	d 36	2

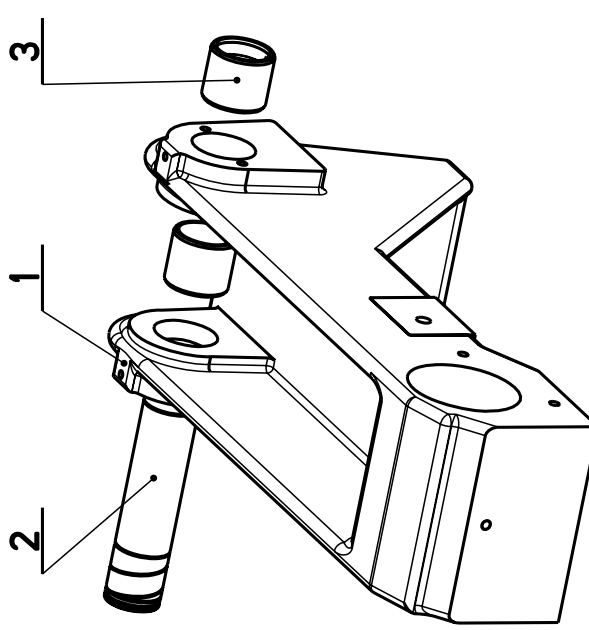

6.27. Klíč / Schlüssel / Key

Cislo Sestavy 201.K114-100		Ver. 0	Název sestavy KLIC/KEY/SCHLÜSSEL	
Poz.	Objednací číslo	Ver.	Název položky	Rožmer
1	30.K114-101	0	KLIC / KEY / SCHLÜSSEL	
2	30.K114-102		TYC / POLE / STANGE	d 12
3	30.K114-104	0	KLIC / KEY / SCHLÜSSEL	P4x80

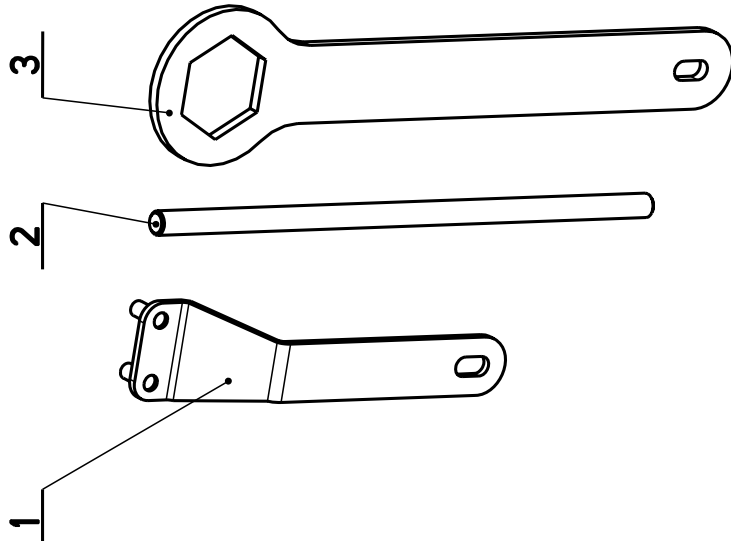

Cislo Sestavy/Number of assembly/Nummer der Baugruppe; Verze (Ver.)/Version/Version; Název sestavy/Assembly title/Name der Baugruppe; Pozice (Poz.)/Position/Position;
 Objednací číslo/Purchase order number/Bestellnummer; Název položky/Volume title/Name der Position; Rožmer/Štok size/Abmessung

6.28. Díl přípojovací /Anschlusssteil / Attachment part

Císlo Sestavy 201.K314-200	Ver. 0	Název sestavy DÍL PŘIPOJOVACÍ / ATTACHMENT PART / ANSCHLUSSTEIL			
Poz.	Objednávací číslo	Ver.	Název položky	Rozměr	Ks
1	30.K103-027	0	SROUB / BOLT / SCHRAUBE	SROUB 12x20	M330, M430 2
2	30.K314-210	0	PROFIL L / PROFILE L / PROFIL L	L 70x70x6	1
3	90.001.25.037	0	SROUB IMBUS / ALLEN HEAD BOLT / IMBUSSCHRAUBE	M8x45	2
4	90.001.25.056	0	SROUB IMBUS / ALLEN HEAD BOLT / IMBUSSCHRAUBE	M12x20	2
5	90.100.55.005	0	MATICE / NUT / MUTTER	MATICE _ M8	2
6	90.150.50.005	0	PODLOŽKA / WASHER / UNTERLEGSCHEIBE	PODLOŽKA 8,4	4
7	90.150.50.007	0	PODLOŽKA / WASHER / UNTERLEGSCHEIBE	PODLOŽKA 13	2
8	90.151.50.005	0	PODLOŽKA / WASHER / UNTERLEGSCHEIBE	PODLOŽKA 8	2

