

## **Workline 410.280 RB**

Operating instructions

**Before transporting and using the machine,  
please read the instructions thoroughly!**

# Service and information

Your BOMAR dealer:

## Direct BOMAR contact:

**BOMAR spol. s r.o.**  
Těžební 1236/1  
62700 Brno  
Czech Republic, EU

telefon: +420 – 533 426 100  
fax: +420 – 533 426 109  
e-mail: [info@bomar.cz](mailto:info@bomar.cz)  
www: <http://www.bomar.cz>

## We are available:

Mondays to Fridays

7<sup>00</sup> – 16<sup>00</sup>

## Version:

1.00 / June 2012  
rev. 1

**BOMAR, spol. s r.o.** © – Subject to modifications and amendments.





# Content

<b>1. SAFETY NOTES .....</b>	<b>7</b>
1.1. Machine determination.....	9
1.2. Protective suit and personal safety.....	9
1.3. Safety notes for machine operator .....	10
1.4. Safety notes for the servicing and repairs .....	10
1.5. Safety notes for the servicing and repairs on hydraulic unit.....	11
1.6. Safety machine accessories .....	11
1.6.1. Total Stop.....	11
1.6.2. Arm covers .....	11
1.6.3. Saw band stretching and rupture inspection.....	11
1.6.4. Band saw cover .....	12
1.6.5. Brush cover .....	12
1.7. Safety notes for the cooling .....	12
1.7.1. Instructions for first help .....	13
1.8. Umístění štítku stroje / Maschinenschild position / Position of machine label .....	13
1.9. Umístění bezpečnostních značek / Verteilung der Sicherheitszeichen / Position of safety symbols.....	14
<b>2. MACHINE DOCUMENTATION .....</b>	<b>15</b>
2.1. Technická data / Technische Daten / Technical data .....	17
2.2. Rozměrové schéma / Aufstellzeichnung / Installation diagram .....	18
2.3. Popis / Beschreibung / Description.....	19
2.4. Transportation and stocking.....	20
2.4.1. Conditions for transportation and stocking.....	20
2.4.2. Transport and stocking preparations.....	20
2.4.3. Transport and stocking .....	20
2.4.4. Transportní schéma / Transport schema / Transport diagram .....	21
2.5. Activation.....	22
2.5.1. Machine working conditions .....	22
2.6. Band saw unpacking and assembling .....	22
2.6.1. Machine installing and levelling .....	22
2.6.2. Machine disposal after lifetime.....	22
2.6.3. First run of the power pack.....	23
2.6.4. Filling the reservoir with hydraulic oil .....	23
2.6.5. Kotevní plán / Verankerungsplan / Grounding plan .....	24
2.7. Electrical connection.....	25
2.7.1. Check the direction of the saw band.....	25
2.7.2. Check machine connection into electrical network.....	25
2.8. Filling of the cooling system .....	26
2.9. Check machine function .....	26
2.10. Saw band.....	26
2.10.1. Saw band size.....	26
2.10.2. Selection of the saw band tooth system.....	26
2.10.3. Saw band running-in.....	27
Tables for teeth selection .....	28
<b>3. MACHINE CONTROL.....</b>	<b>29</b>
3.1. Starting the band saw .....	31
3.2. Control panel .....	32
3.3. Machine control .....	33
3.3.1. Cycle breaking .....	34
3.4. Band saw adjusting .....	35
3.4.1. Adjusting band guides.....	35
3.4.2. Cutting speed adjusting.....	35
3.4.3. Adjustment of pressure to the cut .....	35
3.4.4. Speed adjustment of the arm lowering.....	35
3.4.5. Saw frame lower stop position .....	36
3.4.6. Brush adjustment.....	36
3.5. Material insertion.....	36
3.5.1. Handling agent selection .....	36
3.5.2. Insertion .....	37
3.5.3. Bundle material cutting .....	37
<b>4. MACHINE SERVICE .....</b>	<b>39</b>
4.1. Saw band dismantling .....	41
4.2. Saw band instalation.....	41
4.3. Saw band stretching and inspection.....	42
4.3.1. Saw band stretching.....	42
4.4. Saw band run adjustment on stretching wheel.....	42
4.4.1. Saw band run inspection.....	42
4.4.2. Saw band setting .....	43
4.5. Saw frame lower stop position adjustment .....	43
4.6. Limit switch of the saw frame lower position adjustment.....	44
4.6.1. Check setting.....	44

4.6.2.	Limit switch setting.....	44
4.7.	Cooling agents and chips disposal.....	45
4.7.1.	Coolant device inspection.....	45
4.7.2.	Chips disposal.....	45
4.8.	Hydraulic, Greases and oils.....	46
4.8.1.	Gearbox oils.....	46
4.8.2.	Lubricant greases.....	46
4.8.3.	Lubrication.....	47
4.8.4.	Hydraulic oils.....	47
4.8.5.	Hydraulic unit service.....	48
4.9.	Machine cleaning.....	48
4.10.	Worn pieces replacement.....	49
4.10.1.	Hard metal guides replacement.....	49
4.10.2.	Round brush replacement.....	49
4.10.3.	Saw band guiding rollers replacement.....	50
4.10.4.	Stretching wheel replacement.....	51
4.10.5.	Driving wheel replacement.....	53
4.10.6.	Cooling liquid pump replacement.....	54
<b>5.</b>	<b>ZÁVADY / TROUBLESHOOTING .....</b>	<b>57</b>
5.1.	Mechanical problems.....	58
5.2.	Electric and hydraulic problems.....	60
5.3.	Hydraulic problems.....	61
<b>6.</b>	<b>SCHÉMATA / SCHEMAS / SCHEMATICS .....</b>	<b>63</b>
6.1.	Elektrické schéma / Elektroschema / Wiring diagrams – 3x400 V, TN-C-S.....	64
6.2.	Hydraulické schéma / Hydraulikschema / Hydraulic diagram.....	68
<b>7.</b>	<b>VÝKRESY SESTAV PRO OBJEDNÁNÍ NÁHRADNÍCH DÍLŮ / ZEICHNUNGEN FÜR BESTELLUNG DER ERSATZTEILE / DRAWING ASSEMBLIES FOR SPARE PARTS ORDER .....</b>	<b>71</b>
7.1.	Workline 410.280 RB.....	72
7.2.	Kusovník / Stückliste / Piece list – Workline 410.280 RB.....	73
7.3.	Rameno / Sägerahmen / Saw arm - 1.....	74
7.4.	Kusovník / Stückliste / Piece list – Rameno / Sägerahmen / Saw arm - 1.....	75
7.5.	Rameno / Sägerahmen / Saw arm - 2.....	76
7.6.	Kusovník / Stückliste / Piece list – Rameno / Sägerahmen / Saw arm - 2.....	77
7.7.	Napínání / Spannung / Tensioning.....	78
7.8.	Kusovník / Stückliste / Piece list – Napínání / Spannung / Tensioning.....	79
7.9.	Vedení pásu / Sägebandführung / Belt guide.....	80
7.10.	Kusovník / Stückliste / Piece list – Vedení pásu / Sägebandführung / Belt guide.....	81
7.11.	Vodící kostka / Führungsklotz / Guiding cube - 1.....	82
7.12.	Kusovník / Stückliste / Piece list – Vodící kostka / Führungsklotz / Guiding cube - 1.....	83
7.13.	Vodící kostka / Führungsklotz / Guiding cube - 2.....	84
7.14.	Kusovník / Stückliste / Piece list – Vodící kostka / Führungsklotz / Guiding cube - 2.....	85
7.15.	Pohon / Antrieb / Drive.....	86
7.16.	Podstavec / Untersatz / Base.....	88
7.17.	Kusovník / Stückliste / Piece list – Podstavec / Untersatz / Base.....	89
7.18.	Ovladač panel / Bedienpult / Control panel.....	90
7.19.	Kusovník / Stückliste / Piece list – Ovladač panel / Bedienpult / Control panel.....	91
7.20.	Doraz / Anschlag / Stop piece.....	92

# 1. **Safety notes**





The operating instructions must be read by the person, who keeps in touch with the machine before transportation, installation, using, servicing, reparation, stocking or removal!

The operating instructions include relevant information. The operator must familiarise himself with the install and operation, safety notes and machine servicing, because reliability and service life must be reached. The operating instructions must avoid risks, which are linked to work on the machine. Before transporting and using of the machine, please read the instructions thoroughly!

**Attention!**

*The operating instructions must be available at the machine!  
Keep the operating instructions in good condition!*

## 1.1. Machine determination

The band saw **Workline 410.280 RB** is determined for cutting and shortening of rolled bars and drawn bars and profiles from steels, stainless steels, non-ferrous metals and plastics **with cutting angle** from  $-60^{\circ}$  to  $60^{\circ}$ .

**Combustible materials are excluded for cutting!** Any other usage and operation outside this range are unauthorized and the manufacturer/supplier does not accept any responsibility for any damages resulting from such misuse. **The operator has full responsibility!**

The machine is equipped with safety and protective guarding for operator and machine protection. Nevertheless, this safety and protective guarding cannot prevent injury. Service personnel must read this chapter and comprehend it, before he starts to work on the machine. **Always keep instructions about work safety!** Service personnel must take into account other aspects of the risk, which refer to the ambient conditions and the material.

**Attention!**

*Consider the safety signs on the machine. Do not remove or damage them!*

## 1.2. Protective suit and personal safety

**Wear tight fitting overalls!** Loose fitting clothes may be caught with machine parts and cause serious injury.

**Wear protective gloves!** Material cuts and saw band have sharp edges and may cause serious injuries.

**Attention!**

*Gloves you can use only at working material replacement (saw band)! The machine and accessories must be inactive!  
If the machine is running, you must not wear gloves! It is dangerous, because some parts of the machine can catch gloves!*

**Wear protective shoes with non-skid soles!** The unsuitable shoes may cause balance loss and following injury. Falling work pieces may cause serious injuries too.

**Wear protective goggles!** Chips and cooling liquid may damage your eyes.

**Always wear ear protections!** Most of the machines emit up to 80 dB and may damage your hearing.

**Do not wear jewellery and always tie back long hair!** Moving machine parts can catch jewellery or loose hair and may cause serious injuries.

**Operate the machine only when you are fit enough to work.** Illnesses or injuries diminish concentration. Avoid machine work, which may compromise the safety of you and your colleagues!

### 1.3. Safety notes for machine operator

**Attention!**

*Machine can be operated by person older than 18 years!  
Machine can be operated only person physically and mentally fit for this activity*

Machine can be operated only by one person. Machine operator is responsible for presence of other persons by the machine.

**Keep instructions and orders about work safety!**

*Read the operating instructions, before you start to work on the machine! Keep the operating instructions in good condition!*

Close covers before the machine starting and check, if the covers are not damaged. Damaged covers must be repaired or changed. Do not start the machine, if the cover is removed! Check, if the electric cables are not damaged.

**Attention!**

***Do not connect the machine to electricity if the covers are removed. Do not touch the electrical equipment.***

- Do not hold the material for clamping to the vice and for cutting!
- Do not operate with the buttons and the switches on the control panel, when you have gloves!
- For machine starting take care, that there is nobody in the working area of the machine (it means in the working area of the vice, the saw band, the saw arm etc.).
- In no circumstances touch the rotating elements.
- Work on the machine only when the machine is in good condition!
- Check at least once in a shift, if the machine is not damaged. If the machine is damaged, you must bring the machine in order and you must inform your superior!
- Keep your working area clean! Ensure sufficient lighting in the working area.
- Take off the spilt water or the oil from the floor and dry it. Do not touch the cooling liquid with bare hands! Do not set the nozzle of the cooling liquid, when the machine is started on
- Do not remove the chips from the working area of the machine, when the machine is started on!
- Do not use the compressed air for the machine cleaning or for the chips removing!
- Use the protective instruments for chips removal!

### 1.4. Safety notes for the servicing and repairs

**Attention!**

*Only a qualified professional can carry out the servicing and repairs of the electric equipment! Take special care during the work with electrical equipment. High voltage shock can have fatal consequences! Always keep notes about work safety! Otherwise, there is possibility of heavy injury!*

Switch off the main switch and lock it, before you start service work! Otherwise, there is possibility of hazardous machine starting.

Only qualified person can do the servicing and repairs. For parts changing, use only parts, which are identical with the originals. Otherwise, there is possibility of health hazard. Use only recommended type of the hydraulic oils and oils and lubricants!

Do not remove or do not lock the limit switches or safety equipments! Any use of the saw, accessories or machine parts other than that intended by the BOMAR, spol. s r.o. company is not permitted. The guarantee on this product will be afterward lost and BOMAR, spol. s r.o. takes no responsibility for caused damages.

### 1.5. Safety notes for the servicing and repairs on hydraulic unit

Compliance with the the principles of cleanliness is basic requirement for trouble-free operation of hydraulic equipment. Hydraulic components are products made with high accuracy, and any contamination leads to a reduction lifetime or even malfunction. The consequences are very difficult to remove and expensive.

Always use clean tools. Parts and fasteners, which are part of a hydraulic circuit, never put away the dirty surface. The best cleaning agent is crepe paper, because the fibers of the cleaning cloths can also cause malfunction.

Protective cap from the threaded chamber remove just before the assembly of the unit.

Hoses and pipes before mounting flush with gasoline or other cleaning agent and blow compressed air.

All fittings must be properly tightened. However, do not raw power.

### 1.6. Safety machine accessories

The machine is equipped with safety accessories. It protects the operator from injuries and the machine before damage. The safety accessories are blocking accessories, emergency switches and covers. Check once in a week the function of the safety accessories. If the safety accessories are functionless, you must stop work and repair or change the safety accessories.

#### **Enhanced risk!**

*Do not come into or intervene in the cutting area. Otherwise, there is possibility of heavy injury.*

#### 1.6.1. Total Stop

**TOTAL STOP** button is used for emergency switching – off the machine in case defect or health hazard. By pressing **TOTAL STOP** button is interrupted the supply of the electrical power.

**If any damages or fault appears, immediately press TOTAL STOP button!** Release the pressing button is possible by twisting of the upper part of the button.

#### 1.6.2. Arm covers

If the cover is opened during operation, the limit switch is opened and the band saw is stopped. The band saw is not possible to start in set mode.



**The band saw is stated to the operation, when the covers is closed!** Limit switche on saw arm control if covers are open or not.

#### 1.6.3. Saw band stretching and rupture inspection

This device checks the saw band stretching and causes immediate machine shut – down in the event the band ruptures.

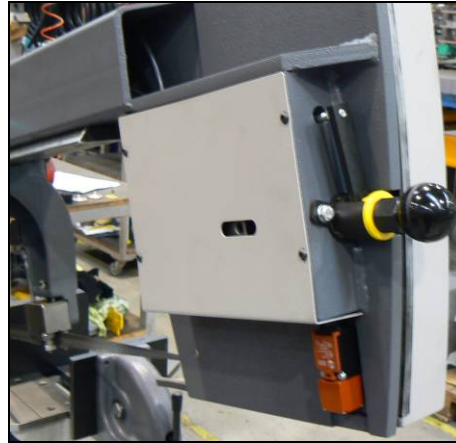

The device contains limit switch. Check the stretching carefully and periodically – eventually adjust.

#### 1.6.4. Band saw cover

It covers the visible area of the saw band from left guiding cube to the frame.



Never switch on the saw band driver if this cover is not mounted!

#### 1.6.5. Brush cover

It covers the brush for saw blade.



Never switch on the saw band driver if this cover is not mounted!

### 1.7. Safety notes for the cooling

#### **Attention!**

- *When handling cooling agents always wear hazardous fluid-proof gloves!*
- *Wear protective goggles!*
- *Cooling liquid can get in contact with your eyes and may cause permanent severe injuries*

### 1.7.1. Instructions for first help

1. Pull off and safely remove polluted, soaked clothing.
2. For breathing, go out in the fresh air or look for first aid treatment.
3. Wash with water or use crèmes for contact with the skin.
4. Flush with water for eyes and look for first aid treatment.
5. For swallowing, drink a lot of water and induce vomiting. Look for medical help.

### 1.8. Umístění štítku stroje / Maschinenschild position / Position of machine label

Umístění štítku stroje /  
Maschinenschild position /  
Position of machine label

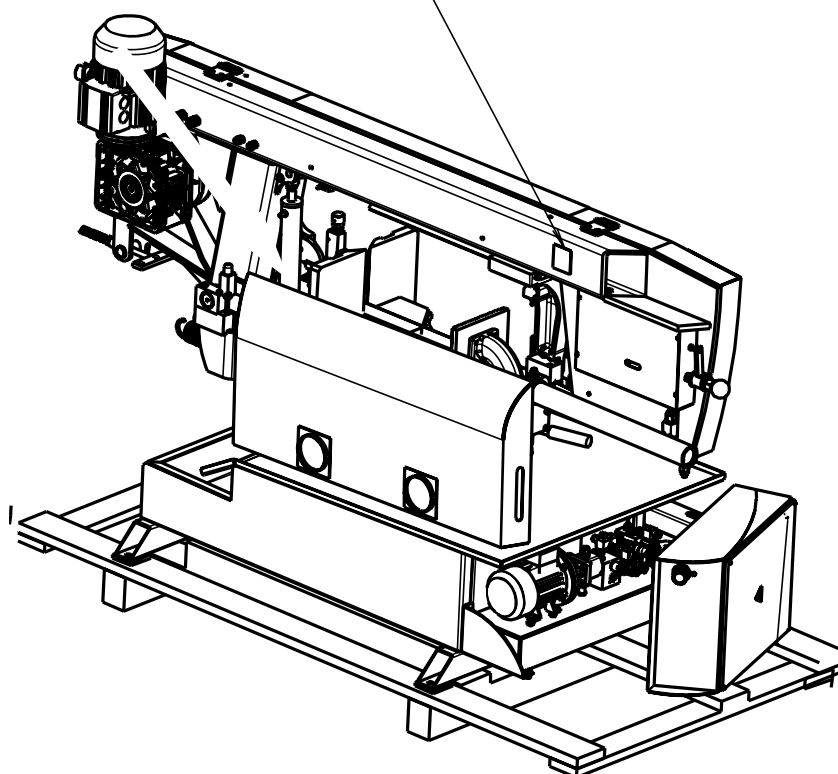

## 1.9. Umístění bezpečnostních značek / Verteilung der Sicherheitszeichen / Position of safety symbols

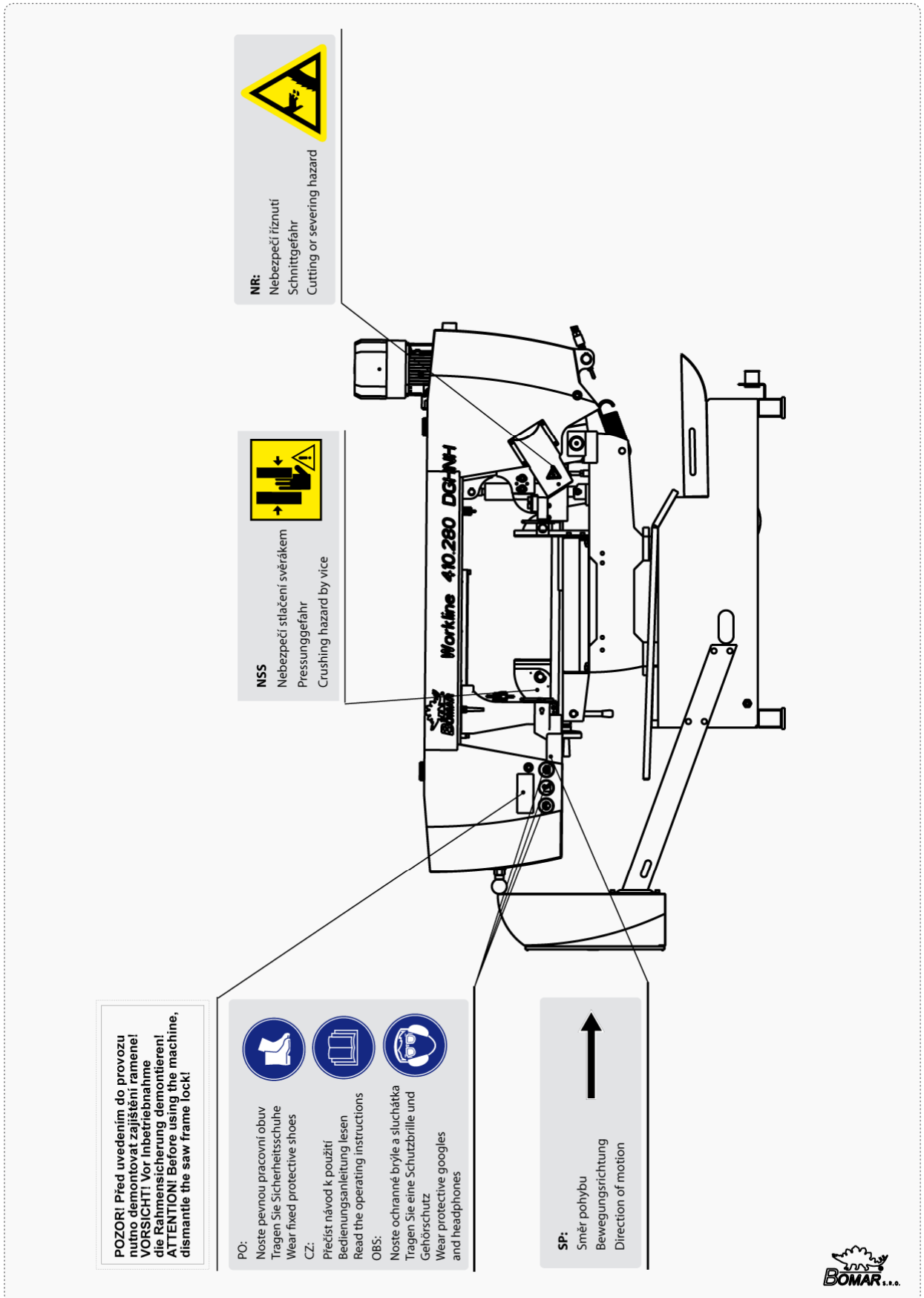





## 2. **Machine documentation**



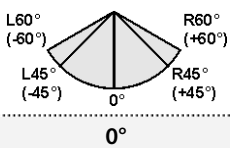

## 2.1. Technická data / Technische Daten / Technical data

<b>Hmotnost stroje / Maschinengewicht / Machine weight:</b>				
• Hmotnost / Gewicht / Weight	570 kg			
<b>Rozměry stroje / Maschinengröße / Machine size :</b>				
• Délka / Länge / Length	2130 mm			
• Šířka / Breite / Width	1070 mm			
• Výška / Höhe / Height	1440 mm			
<b>Elektrické vybavení / Elektrische Ausrüstung / Electrical equipment:</b>				
• Napájení / Versorgungsspannung / Supply voltage	~3 x 230 V, 50Hz, TN-C			
• Příkon / Gesamtschlusswert / Total Input	2,7 kVA			
• Max.jištění / Max. Vorschaltsicherung / Max. Fuse	16 A			
• Krytí / Schutzart / Protection	IP 54			
<b>Akustický tlak / Schalldruckpegel / Acoustic pressure:</b>				
• Workline 410.280 RB	$L_{Aeqv} = 76,3$ dB			
<b>Pohon / Atrieb / Drive:</b>				
• Typ / Typ / Type	TM90 4X B14-E3.2			
• Napájení / Versorgungsspannung / Supply voltage	~3x230V, 50Hz			
• Výkon / Leistung / Output	2,2 kW			
• Jmenovité otáčky / Motornendrehzahl / Nominal speed	1440 min <sup>-1</sup>			
<b>Hydraulické zařízení / Hydraulikeinrichtung / Hydraulic equipment:</b>				
• Typ / Typ / Type	PPM-AC0,37-PG1/2,5-TM16-CB03-FR			
• Výkon / Leistung / Output	4 MPa			
<b>Chladicí zařízení / Kühlmiteleinrichtung / Cooling equipment:</b>				
• Typ / Typ / Type	MICRONISER			
• Obsah nádrže / Volumen vom Kühlmittel / Capacity	0,5 l			
<b>Rozměr pásu / Sägebandedimension / Band size:</b>				
<b>3800×27 (25)×0,9 mm</b>				
<b>Řezná rychlost / Schnittgeschwindigkeit / Cutting speed:</b>				
<b>20–120 m/min.</b>				
<b>Řezné rozsahy / Schnittbereiche / Cutting size:</b>				
	 280			

### Warning:

If the material detection device is installed on the machine then maximal workpiece height is 10 mm shorter.

### Level of acoustic pressure:

Equivalent level of acoustic pressure A (noise) at operator position are  $L_{Aeqv}=76,3$  dB. Mentioned values are levels of emission which doesn't have to represent safe levels. Factors which influence real level of acoustic pressure on machine operator are: working place characteristics, cut material, saw band. These factors have significantly influence on acoustic pressure.

2.2. Rozměrové schéma /  
Aufstellzeichnung /  
Installation diagram

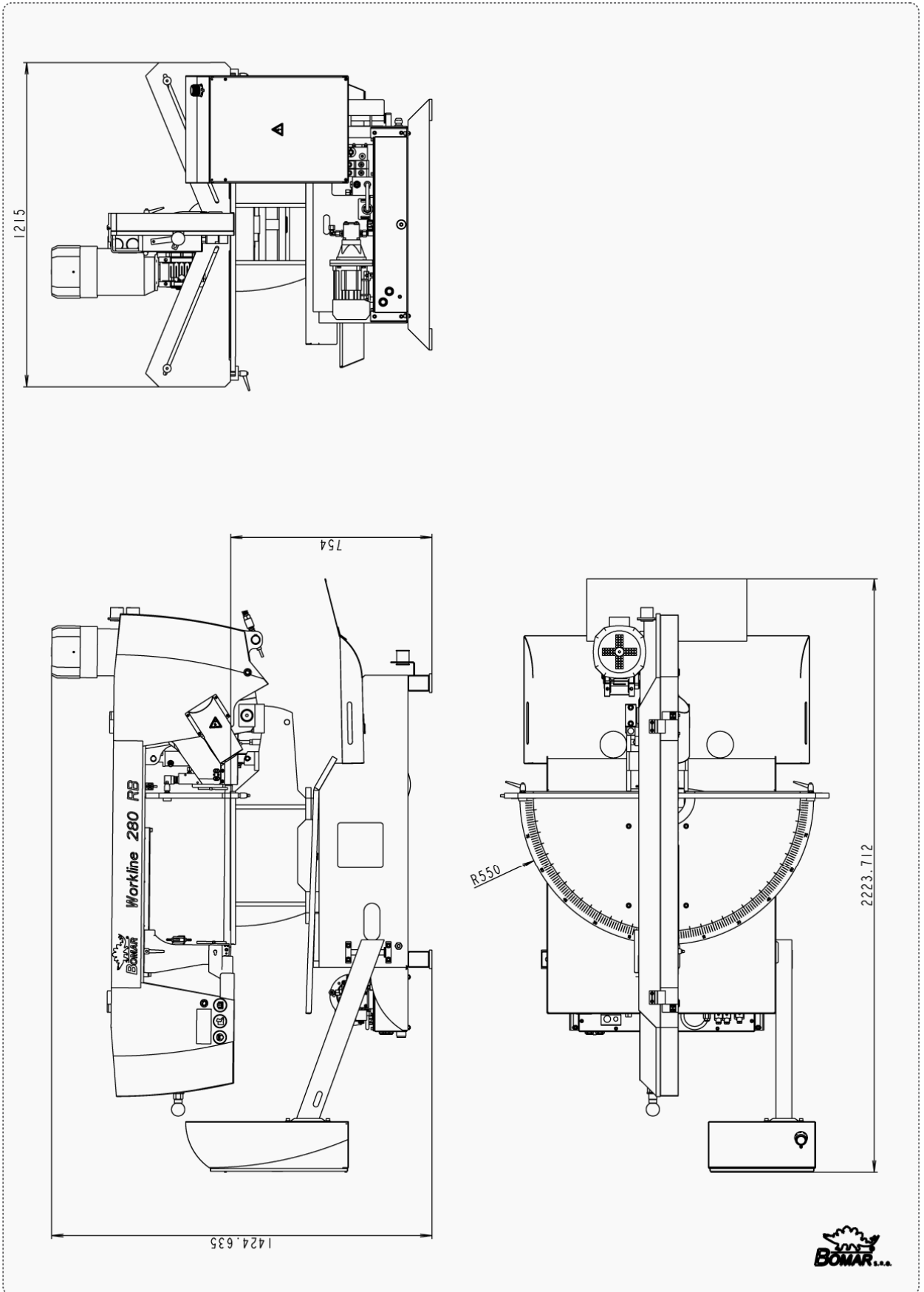

### 2.3. Popis / Beschreibung / Description

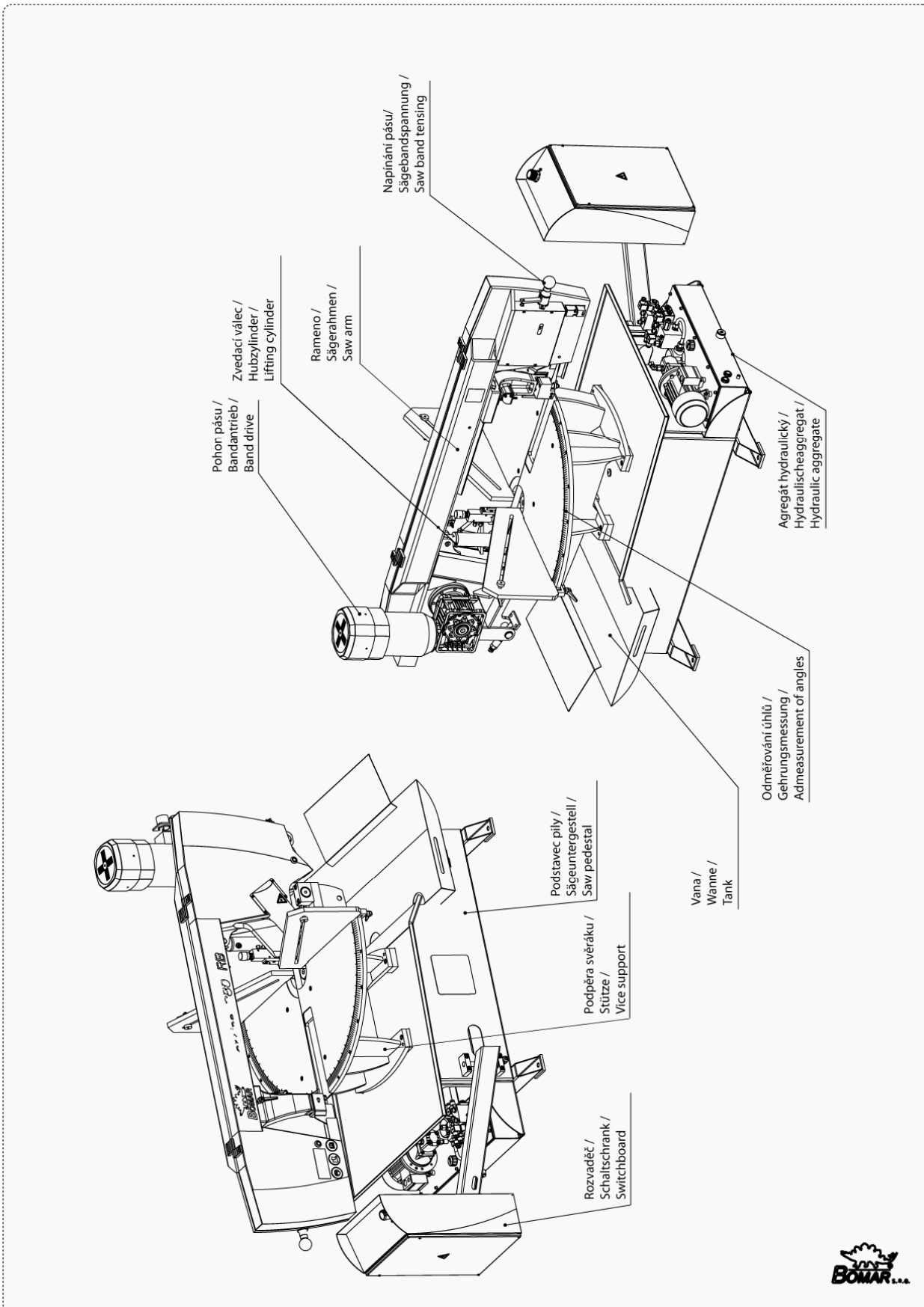

Dokumentace stroje  
 Dokumentation der Maschinen  
 Machine documentation

## 2.4. Transportation and stocking

### 2.4.1. Conditions for transportation and stocking

Keep recommendations for the manufacturers for transportation and stocking! If the recommendations are not kept, damage can occur to the machine.

- Don't use a forklift truck for handling the machine, if you do not have license for it!
- Don't move under suspended loads! Fault in lifting device may cause serious injury.
- Keep a safe distance from the machine during the transport.
- Temperature of the air from  $-25^{\circ}\text{C}$  to  $55^{\circ}\text{C}$ , for a *short term* (max. 24 hours) temperature of the air until  $70^{\circ}\text{C}$
- Do not expose the machine to radiation (for example microwave radiation, ultraviolet radiation, laser radiation, x-ray radiation). Radiation can cause problems with the machine function and deteriorating condition of the isolation.
- Take measures, to prevent damage by dampness, by vibrations and by shakes.

### 2.4.2. Transport and stocking preparations

Close the vice and thoroughly oil all blank surfaces.

Lower the saw frame to the lowest position.

Make sure to empty the machine of all traces of the cooling agent.

Fasten all loose parts securely to the machine.

Pack and wrap the control desk securely to avoid damage during transport.

Fix the stickers stating the minimum approximate machine weight to at least five well visible places.

### 2.4.3. Transport and stocking

The machine must be secured during transportation. Screw on the palette to the floor of the van or the trailer. Be careful that the machine is not damaged during transportation. Store the machine only under conditions mentioned in the manual, to avoid damage of the machine.

It is forbidden to handle the machine any other way, than it is written in this operating instructions, the machine can be damaged.

2.4.4. Transportní schéma /  
 Transport schema /  
 Transport diagram

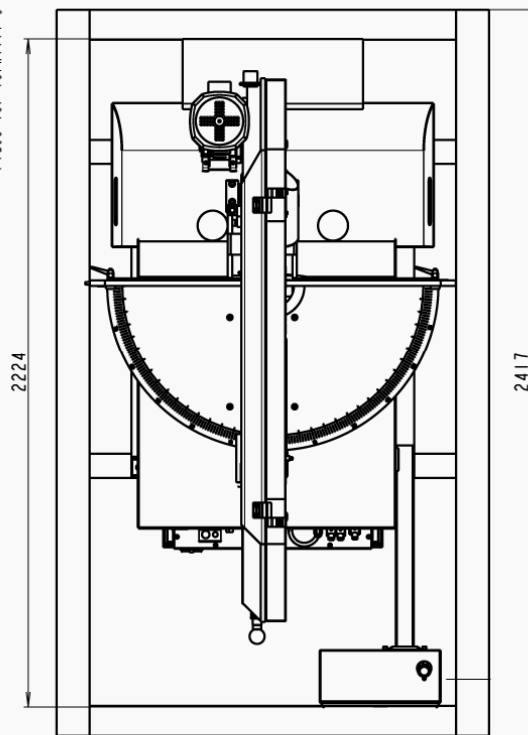
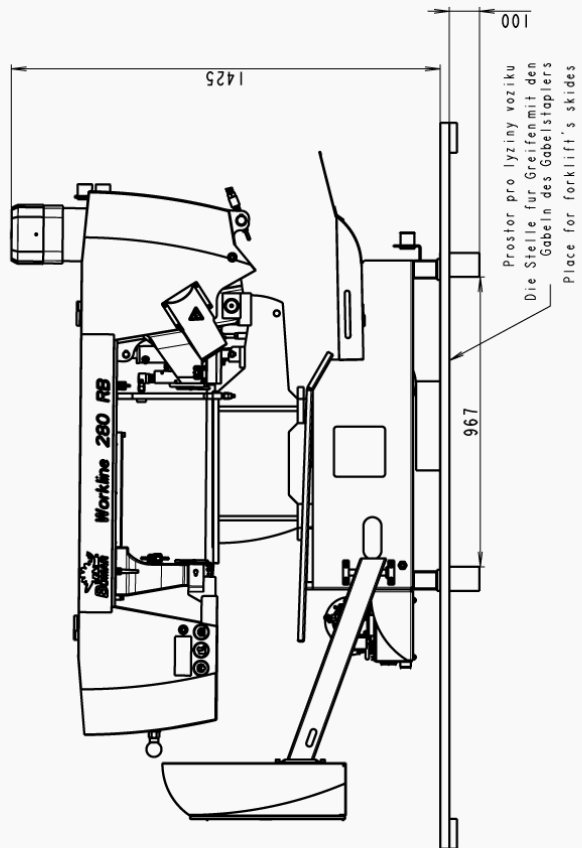
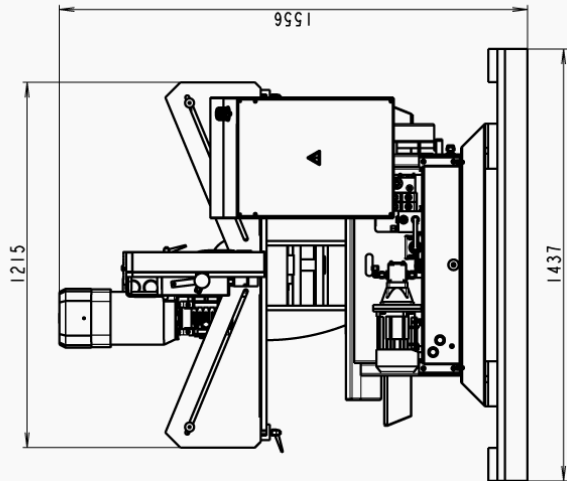

## 2.5. Activation

### 2.5.1. Machine working conditions

Keep the conditions of the manufacturer for machine operating! If recommendations are not kept, damage can occur to the machine.

**The manufacturer warrants the correct function of the machine for these conditions:**

- At temperature air from **5°C to 40°C**, the temperature average during 24 hours must **not exceed over 35°C**.
- At relative dampness of the air in the extend from 30% to 95% (not concentrate). Altitude lower than 1000 metres.
- Do not expose the machine to the radiation (for example microwave radiation, ultra-violet radiation, laser radiation, x-ray radiation). Radiation can cause problems with the machine function and deteriorating condition of the isolation.

**Attention!**

*If the ambient temperature drops below 15 ° C is required before operating the machine to have switch on hydraulic unit around 10 minutes and then made several motion few times (for example, in manual mode) by all hydraulic cylinders. The reason is to heat hydraulic oil to the operating temperature for proper function of the pressure switches (and choke).*

## 2.6. Band saw unpacking and assembling

Remove the packing from the machine and unpack all parts.

**Attention!**

*Switch off the main switch and lock it, before you start assembly! Otherwise, there is possibility of hazardous machine starting.*

If the hydraulic unit is outside the machine (the machine only connected hoses and cables), it needs to be placed and mounted on a solid basis (floors, etc.). The mounting holes are used on the bottom (bases) of the tank.

### 2.6.1. Machine installing and levelling

Check the floor supporting capacity before machine installing. If the floor capacity does not agree with requirements, you must prepare the necessary base for the machine.

**Minimal requirement:**

machine weight – Workline 410.280 RB – 570 kg

+ weight of accessories

+ maximum weight of material

- The machine must be levelled at the horizontal position. All feet of the machine must touch with the floor after levelling
- The machine must be levelled by means of the calibrated spirit level. Spirit level is put on the vice area. Set the roller conveyors according to the spirit level.
- For machine levelling, take care that there is sufficient available space for operation, repair work, servicing of the machine and handling the material..
- The machine including appended parts and accessories must be visible from the place of operation.

### 2.6.2. Machine disposal after lifetime

Blown out all service fluids (cooling liquid, hydraulic oil) into designated reservoir. Dismantle machine into separate parts and dispose them in accordance with valid directives.

### 2.6.3. First run of the power pack

#### Before the first run check:

- The direction of the Pump, while run the power pack for max. 2seconds.
- The cooling fan of the motor has to rotate in the same direction as the arrow on the top of the motor cowling indicates.
- In case of wrong rotational direction, the electrical phase in the connection box is to be changed. This check is required after every disconnection from the power source
- Wiring matches with electrical and hydraulic diagrams
- the electric motors (pump and cooler) are properly connected and have the prescribed rotation
- the hydraulic accumulator with nitrogen gas to the specified value
- aux. elements work right (thermometer, level gauge, heater)

#### First run (Attention – working pressure on securing valve is set by producer in accoring the hydraulic diagram):

- In the short intervals activate an electric pump
- check for leaks and noise
- Bleed the hydraulic circuit
- if possible, test the circuit function with minimum load
- test the electrical equipment
- during operation monitor measuring equipment, noise, height and temperature of oil in the tank
- During this time a careful bleeding off for the whole hydraulic system is necessary. In case there is no bleeder port, the power pack will bleed itself after a while via the air breather on the tank or the return line filter.
- After multiple start-up.

### 2.6.4. Filling the reservoir with hydraulic oil

Oil regulations and recommendations of the manufacturer in the technical documentation (appendix) are to be carefully observed. For standard power packs we recommend the oily type OH-HM32 (DIN 51524) of all known oil manufacturers.

Power packs have to be filled up with clean, pre-filtered oil! The purity of the hydraulic fluid must correspond to the class 10 NAS 1638 (reachable with filter  $\beta = 75$ )!

Filling from container, such as barrels, buckets, etc. is not recommended or permitted!

The maximum oil level will be shown on the upper marking at the dipstick or the sight level glass. Overfilling has to be prevent. The maximum filling rate of 15 l/min shouldn't be exceed.

Oil type	Kinematic viscosity $\nu$ in $\text{mm}^2/\text{s}$ in relationship to the fluid temperatur					Freezing point °C
	0°C	20°C	40°C	60°C	80°C	
OH-HM 32	220	100	32	15	7	-40
OH-HM 46	400	170	46	18	11	-30
OH-HM 68	700	170	68	26	14	-28
OH-HV 32	180	67	32	17	11	-40
OH-HV 46	350	110	46	25	14	-36

## 2.6.5. Kotevní plan / Verankerungsplan / Grounding plan

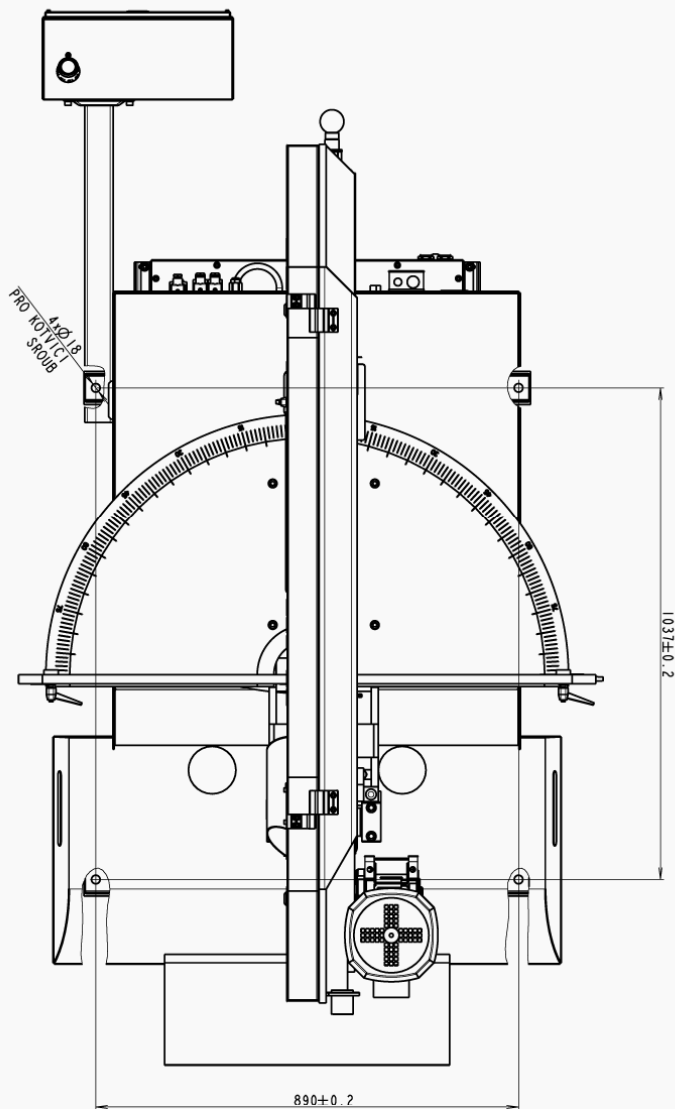

### Kotvící materiál / Verankerungsmaterial / Grounding material

- 4x Hmoždina / Dübel / Plug –  $\varnothing 12$  mm
- Vrtáno do hloubky / In die Tiefe gebohrt / Drilled to – 95 mm
- Šrouby / Schraube / Screws – M16×135

- Šrouby podložit deskami o min. rozměrech P10×100-100
- Die Schrauben mit Platten mit Minimaldimensionen P10×100-100 unterlegen
- Screw must be bottomed with plates (min. dimensions P10×100-100)

### Požadavky na rovinnost podlahy / Anforderungen an die Bodenebenheit / Requirements for floor flatness

± 10 mm / 1 m



## 2.7. Electrical connection

### **Attention!**

**Only a qualified professional must carry out the servicing and repairs of the electric equipment!** Take special care during work with electrical equipment. High voltage shock can have fatal consequences! Always keep notes about work safety.

### Electrical parameters of the machine:

- Service voltage: ~ 3x400 V, 50 Hz, TN-C-S
- Total input / Max. fuse: 2,7 kVA / 16 A

Before connecting switch off the main switch of the power supply circuit for the machine and ensure dry place when doing connecting works!

### **Note:**

*The values of the crosscut of the conductor and the rated current are in the norms.*

*Service voltage must agree with the line voltage! Crosscut of the supply line must respond with rated current for max. machine load.*

### **Note:**

*The socket with the fork can be used only at the machines with the rated current less than 16 A and total input less than 3 kW.*

In case the machine is connected with a direct connection, an extra main switch must be added which can be locked in zero position.

### **Attention!**

*In this case the extra main switch becomes primary and the main switch on the machine has only secondary function.*

### 2.7.1. Check the direction of the saw band



After the machine has been successfully connected, briefly switch on the machine and put the driving engine of the band in the running position. The direction must be in accordance with the arrow direction on the saw band cover. In case the direction of the saw band does not match, two phases at the terminal strip must be switched.

### **Attention!**

*When you connect the machine to the electrical network observe correct connection of all phases!*

**ENGINE IN IN HYDRAULIC AGGREGATE CANNOT BE OPERATED WITH REVERSE TURNING MORE THEN 10 SECONDS!!!**

### 2.7.2. Check machine connection into electrical network

## 2.8. Filling of the cooling system

Prepare the mixture of the water and the cooling liquid. Keep the concentration specified by manufacturer. Shift away the cover from the drainage hole. Fill the mixture of the water and the cooling liquid to the tank of the cooling system. Area of the tank for the cooling liquid is discovered from the chapter *Technical data*.

Let the drainage hole opened and with the sieve during operation, because it secures the right work of the cooling system. Filling the tank with the cooling liquid, take care that the liquid does not drip out of the tank and the tank does not overflowed.

**Note:**

*If machine is equipped with microniser, fill microniser with prescribed cooling liquid. This made the Microniser ready for use.*

## 2.9. Check machine function

Check, if the machine or some parts of the machine were not damaged during transport.

Check, if covers are installed and functional. Check by means of the Tenzomat if the saw band is correctly stretched. If it is necessary, you can stretch the saw band according to chapter *Selection and replacement of the saw band*. Values of the saw band stretching are on the Tenzomat. Switch on the main switch and check the motors and systems (saw band drive, hydraulic pump, cooling pump, chips conveyor).

Open and close the main vice. Turn the saw frame of the band saw from one outer position to other outer position. Raise the saw frame to the top position and drop the saw frame to the lowest position.

Start the machine with the cooling pump and let it run without load until the cooling system will be filled with cooling liquid. As soon as the cooling liquid starts to escape from the nozzles of the cooling system, the cooling system is ready for the operation. Carry one cycle of cutting without material. Check, if the machine runs with no irregularities. If all machine functions are right, the machine is ready for operation..

## 2.10. Saw band

Refit the saw band cover only after you have installed and tightened the saw band.



### 2.10.1. Saw band size

**3800×27 (25)×0,9 mm**

### 2.10.2. Selection of the saw band tooth system

The manufacturers provide the saw bands with constant and variable tooth system. The important factor for selection of the tooth system is length of the cutting canal with respect to the size of the product

1. *Constant tooth system* – the saw band has parallel tooth pitch all over length. This way is suitable for cutting of solid material.

**BOMAR recommended Variable tooth system for band saw.**

2. *Variable tooth system* – tooth pitch is variable. Variable tooth system is used for profiled materials and bundle cutting. Variable tooth pitch lowers vibration of the saw band, increases service life of the saw band and quality of the cutting area.

In tables, there are advised type of the tooth system depending on sizes and form of the cutting material.

**Footnotes:**

Z<sub>1</sub>Z<sub>2</sub> – teeth number on one inch S – tooth with zero angle of the teeth K – tooth with positive angle of the teeth

**Examples of the tooth system marking:**

32 S – number „32“ means 32 teeth on one inch (that means constant tooth system), letter „S“ marks teeth with zero angle of the tooth.

4–6 K – number „4–6“ means 4 till 6 teeth on one inch (that means variable tooth system); letter „K“ marks teeth with positive angle of the teeth.

### 2.10.3. Saw band running-in

**Running-in:** Cut the material with the frame lowering reduced to 50% only. When vibrations occur increase or decrease the band speed.

When cutting small pieces run the band until approximately 300 cm<sup>2</sup> of material has been cut. When cutting large pieces run the band for 15 minutes approximately. When the band has been run, increase the lowering-speed to normal speed. The running in of the saw band avoids micro-breaks on the cutting edges of new saw band ensuing from first excessive stress. This would decrease service life substantially. The optimal running in of the saw band produces ideal rounded cutting edges and therefore the conditions for an optimal service life.

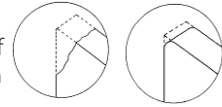

**Note:** Run regrinding saw bands too.

### Tables for teeth selection

SHAPED MATERIAL ( $D_p, S = \text{mm}$ )						
Note: Table shows tooth system selection for cutting one piece of the profile. For cutting of more pieces of the profiles (bundle), you must think of the size of the wall as double size of the wall of one profile (that means, size „S“ equates to 2xS). In table, there are tooth systems constant and variable.						
Size of the wall S [mm]	Tooth system ( $Z_pZ$ )					
	Outer diameter of the profile $D_p$ [mm]					
	20	40	60	80	100	120
2	32 S	24 S	18 S	18 S	14 S	14 S
3	24 S	18 S	14 S	14 S	10-14 S	10-14 S
4	24 S	14 S	10-14 S	10-14 S	8-12 S	8-12 S
5	18 S	10-14 S	10-14 S	8-12 S	6-10 S	6-10 S
6	18 S	10-14 S	8-12 S	8-12 S	6-10 S	6-10 S
8	14 S	8-12 S	6-10 S	6-10 S	5-8 S	5-8 S
10	-	6-10 S	6-10 S	5-8 S	5-8 S	5-8 S
12	-	6-10 S	5-8 S	5-8 S	4-6 K	4-6 K
15	-	5-8 S	5-8 S	4-6 K	4-6 K	4-6 K
20	-	-	4-6 K	4-6 K	4-6 K	3-4 K
30	-	-	-	3-4 K	3-4 K	3-4 K
50	-	-	-	-	-	3-4 K
Size of the wall S [mm]	Tooth system ( $Z_pZ$ )					
	Outer diameter of the profile $D_p$ [mm]					
	150	200	300	500	750	1000
2	10-14 S	10-14 S	8-12 S	6-10 S	5-8 S	5-8 S
3	8-12 S	8-12 S	6-10 S	5-8 S	4-6 K	4-6 K
4	6-10 S	6-10 S	5-8 S	4-6 K	4-6 K	4-6 K
5	6-10 S	5-8 S	4-6 K	4-6 K	4-6 K	3-4 K
6	5-8 S	5-8 S	4-6 K	4-6 K	3-4 K	3-4 K
8	5-8 S	4-6 K	4-6 K	3-4 K	3-4 K	3-4 K
10	4-6 K	4-6 K	4-6 K	3-4 K	3-4 K	2-3 K
12	4-6 K	4-6 K	3-4 K	3-4 K	2-3 K	2-3 K
15	4-6 K	3-4 K	3-4 K	2-3 K	2-3 K	2-3 K
20	3-4 K	3-4 K	2-3 K	2-3 K	2-3 K	2-3 K
30	3-4 K	2-3 K	2-3 K	2-3 K	1,4-2 K	1,4-2 K
50	2-3 K	2-3 K	2-3 K	1,4-2 K	1,4-2 K	1,4-2 K
75	-	2-3 K	1,4-2 K	1,4-2 K	1,4-2 K	0,75-1,25 K
100	-	-	1,4-2 K	0,75-1,25 K	0,75-1,25 K	0,75-1,25 K
150	-	-	-	0,75-1,25 K	0,75-1,25 K	0,75-1,25 K
200	-	-	-	0,75-1,25 K	0,75-1,25 K	0,75-1,25 K
SOLID MATERIAL ( $D = \text{mm}$ )						
Constant tooth system				Variable tooth system		
length of the cut D		tooth system ( $Z_pZ$ )		length of the cut D		tooth system ( $Z_pZ$ )
to 3 mm		32		to 30 mm		10-14
to 6 mm		24		20-50 mm		8-12
to 10 mm		18		25-60 mm		6-10
to 15 mm		14		35-80 mm		5-8
15-30 mm		10		50-100 mm		4-6
30-50 mm		8		70-120 mm		4-5
50-80 mm		6		80-150 mm		3-4
80-120 mm		4		120-350 mm		2-3
120-200 mm		3		250-600 mm		1,4-2
200-400 mm		2		500-3000 mm		0,75-1,25
300-800 mm		1,25				
700-3000 mm		0,75				

### 3. **Machine control**



### 3.1. Starting the band saw

- » 1. Switch on the main switch of the band saw. The main switch is situated on the the switchboard.

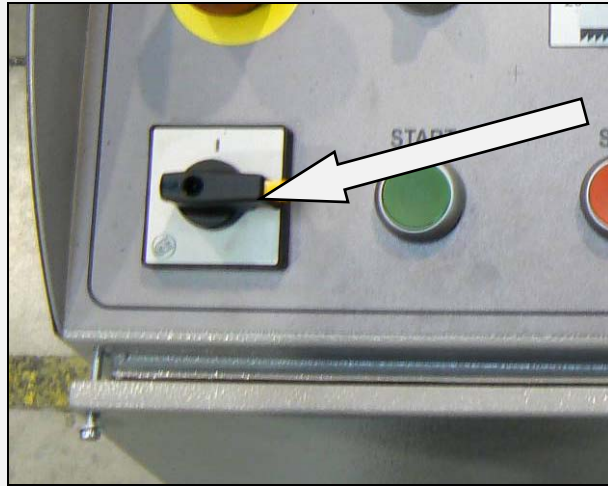

### 3.2. Control panel

Ovládací stroje  
Bedienung der Maschine  
Machine control





<b>1</b>	<p><b>TOTAL – STOP button</b> In emergency causes the machine must be immediately switched off.</p>
<b>2</b>	<p><b>Machine Turn ON/OFF</b> Switch into position 1 to turn ON the machine or into position 0 to OFF.</p>
<b>3</b>	<p><b>Cooling system selection</b> Machine Workline 410.280 RB has only cooling by microniser. For microniser activation choose option with symbol </p>
<b>4</b>	<p><b>START - Switch on the working cycle</b> Push of a button starts the cutting cycle Button STOP stops cutting cycle.</p>
<b>5</b>	<p><b>STOP - Switch off the working cycle</b> Stop cutting cycle.</p>
<b>6</b>	<p><b>Frequency convertor</b> Turn to change the speed of the saw band.</p>
<b>7</b>	
<b>8</b>	<p><b>Lift/Lower the saw arm</b> Pressing and holding button lifts or drops saw arm by the lifting hydraulic cylinder. Lifting the saw arm using the button is not limited by setting on the switch from. 9. After a long shutdown the machine (about days) may temporarily occur that, you cannot lift the arm to the maximum upper position. This gradually improves during the machine operation – after a few strokes. As you move down saw arm, you can activate rapid lowering bypressing both buttons simultaneously.</p>
<b>9</b>	<p><b>Arm height setting</b> According to the scale on the control panel, you can limit the maximum frame top position at the working (semi-automatic cycle). Numbers on the scale indicate the distance between saw blade and vice board near the fixed vice jaw. Limiting the height of the arm can reduce the time of the cutting cycle.</p>
<b>10</b>	<p><b>Governing valve</b> Adjust the speed of the arm sinking to the cut by governing valve. <b>ATTENTION!</b> <b>If you keep closing the throttle valve too tightly, the valve seat may wear off which causes its leakage. Therefore, close the valve always gently.</b></p>

### 3.3. Machine control

1. Lift the saw arm up.
2. Insert the material, that you will to cut.
3. Adjust the arm lift limitation according to the material height.

**Attention!**

*Do not move the saw arm to the material, when the saw band driving is not running! Do not move the saw arm to the material with accelerated motion! The saw band can be damaged!!*

4. Turn the jaws to the cutting material and lock with levers. (arrow 1).

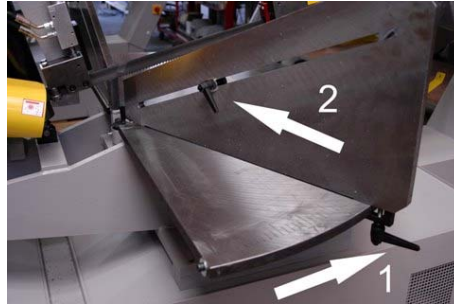

5. Draw close the rolles. (arrow 2).
6. Adjust the guiding cubes to the cutting material.
7. Adjust the speed of the saw band according to the type of the cutting material.
8. Adjust the speed of the arm lowering to the cut.
9. Press button **START** – start of semi-automatic mode

**Attention!**

*You can stop the semi-automatic mode by pressing button **STOP** stop of semi-automatic mode. Press **TOTAL STOP** – emergency button.*

10. Cut the material, lift the arm to the top position, switch off the saw band drive and open the vice.
11. Now, you can repeat all process.

### 3.3.1. Cycle breaking

»

- **STOP button**

Semi-automatic cycle is interrupted by pressing button **STOP** of the cycle

The arm stops fall into cut and saw blade is stoped.

By pressing button **START of the working cycle**, you can start the cycle.

- **TOTAL STOP button**

In case of the risk, press button **TOTAL STOP**.

After pressing **TOTAL STOP** button, saw band drive is immediately broken and the arm sinking is stopped.

- **Reactivation**

1. Turn button **TOTAL STOP** according to the arrows (on the button).
2. Lift saw arm above cutted material and push **START** button.

### 3.4. Band saw adjusting

#### 3.4.1. Adjusting band guides

If you want to achieve a smooth and precise cut, it is helpful to position the guide cube as close as possible to the material.



1. Release the stopping lever of the listel. Move the left part of the guide so that the left edge of the guide blocks is as close as possible cutted material.
2. Lower the frame to the lower position and check the position of the guide cube towards vice loading area. The guide cube must be a distance of at least 10 mm from the vice loading area.
3. Tighten the lever of the gib and check the guide cube setting once more for possible collision with binding table or vice jaw.

#### 3.4.2. Cutting speed adjusting

Blade speed is possible adjusted continuously from 20 to 120 m / min.

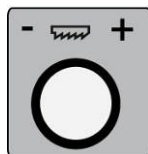

Use the frequency convertor on control panel (pos. 6) to adjust requested speed of the saw band.

#### 3.4.3. Adjustment of pressure to the cut

The band saw **Workline 410.280 RB** is equipped with cutting pressure regulation on the one guiding cube

##### **Upozornění!**

*The guide cubes are equipped with valves, which must be open during operation*

Pressure adjusting is performed with regulating screw on guiding cube.

- **Lower pressure to the cut** – turn the screw clockwise.
- **Higher pressure to the cut** – turn the screw contra-clockwise.

#### 3.4.4. Speed adjustment of the arm lowering

Speed of the arm lowering is adjusted by regulation valve on control panel – pos. 8.

- Set the **lower speed** of the arm lowering to the cut by turning the switch **clockwise**.
- Set the **higher speed** of the arm lowering to the cut by turning the switch **anti-clockwise**.

##### **Notice:**

*If you keep closing the throttle valve too tightly, the valve seat may wear off which causes its leakage. Therefore, close the valve always gently.*

### 3.4.5. Saw frame lower stop position

The lower stop limits the lowest position of the saw frame. This stop point has to be checked at least once a month. If the lower stop point is incorrectly adjusted, the cutting table can be damaged or the material will not be cut completely.

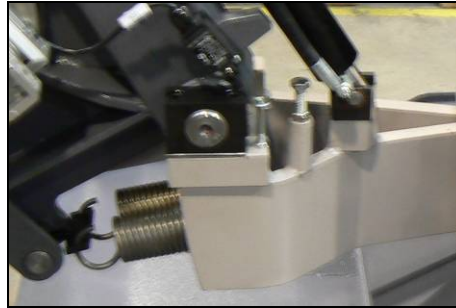

Setting the lower stop position is set using the screw in Console.

### 3.4.6. Brush adjustment

The brush for chip removal from the saw band influences cutting durability saw band lifetime and wheels lifetime, hard metal guides and finally the cut accuracy. Brush adjustment must be checked every shift.

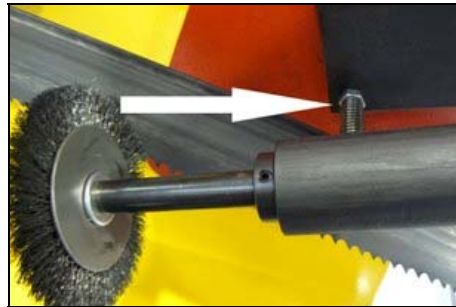

1. Release the fixative screw of the brush. It is possible to move with the brush.
2. Set the brush to the saw band according to the picture.

**Attention!**

*The brush **must not** touch the bottom of the saw teeth!*

3. Tighten the fixative screw.
4. In case, that the brush is not turned right (driving wheel slips on the driving wheels of the saw band), push by means of the screw (see arrow) driving wheel of the brush to the driving wheel of the saw band.

**Attention!**

*The screw must not be tightened with heavy force, because driving wheel of the brush can be damaged or the lifetime of the bearings of the driving wheel of the band can be lowered!*

## 3.5. Material insertion

- Never walk under a suspended load!
- Never climb onto the gravity-roller conveyor!
- Do not hold the material for clamping material to the vice! The vice can cause injury!

### 3.5.1. Handling agent selection

- Use the strong handling agents to lift and transfer the material!

- Handle with the material only with the lift truck or use the suspension strands and the crane!
- Do not use the lift truck or crane in case that you do not have the license to handle with it!

### 3.5.2. Insertion

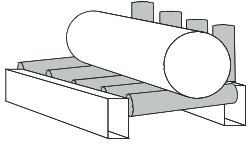

Insert material to the vice and ensure that the material cannot move in the vice or fall from the vice after the clamping. If you cut long pieces of the material (for example rod, tube), you must use the roller conveyors for material shifting to the band saw. Contact Bomar for more information about roller conveyors

Make sure the conveyor is long enough and the material cannot tip off the conveyor.

Be especially careful with round materials that it always stays on two vertical rollers and that it cannot fall off the conveyor!

### 3.5.3. Bundle material cutting

**Attention:**  
*Manual bundle clamping device is not standard equipment.  
Without this device is a not possible cut bundle.*

If you want to cut the material in the bundle, there are suggestions for the positioning of bundles

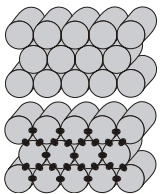

*Round material bundle:* Take care especially with round material that the bars are put according to the picture. If the bars are put differently, you may have problems with movement.

Always weld the material at the rear end of the bundle to secure it from moving.

Before welding always, switch the machine off at the main switch! The magnetic fields, which often occur during welding, may damage the controls!

**Attention:**  
*Not all material shapes are suitable for bundle cuts. Keep the recommendation of your supplier of the saw bands for material insertion to the bundle.*



## 4. **Machine service**





## 4.1. Saw band dismantling

During the dismantling, take care that you do not damage the limit switch if the saw band stretching.

1. Lift the saw frame to the top position. Stop the saw frame in top position by control valve.



2. Dismantle yellow protective cover of the saw band. The cover is clamped with two screws.



3. Open the cover of the arm.
4. Turn by stretching star to the left side, release saw band stretching and pull saw band from blade wheels.



5. Pull up the saw band from the guiding cubes

## 4.2. Saw band instalation

During the installation, take care that you do not damage the limit switch if the saw band stretching!

1. Prior to installation, clean all track wheels, guide cubes and inner side of the arm thoroughly of all traces of chips and dirt. **Keep in mind the teeth direction when installing the saw band.**



2. Insert new saw band in the guide cubes. Make sure the saw band runs between both guide rollers and it is pushed all the way to the top.



3. Put the saw band on both guide wheels. Make sure that the saw band ridge fits tightly to the wheel rim. Then push the saw band as far back as possible.
4. By turning the stretching star to the right, you will stretch the saw band slightly. Remove the plastic cover of the saw band teeth.
5. Close the cover of the arm.



6. Install the yellow protective cover of the band. The arrow on the cover must match the direction of the arrow on the band. If it does not, you must turn the band round.

### 4.3. Saw band stretching and inspection

Right saw band stretching is one of the most important criteria's, which influents accuracy and saw band service life. Stretch the saw bands according to the selected saw band and the band saw. Keep the recommendation of your manufacturer.

#### 4.3.1. Saw band stretching

1. The saw band must not fall from the wheels after setting.
1. Install the Tenzomat on the saw band and secure it with screws.



2. Stretch the saw band until it is stretched to the recommended value

### 4.4. Saw band run adjustment on stretching wheel

Saw band run on the stretching wheel must be regularly inspected. The inspection has to follow every saw band replacement.

#### 4.4.1. Saw band run inspection

If the run is not correct, the following problems may occur:

- **The saw band falls from the wheels** – The saw band and protective cover can be damaged.

- **The saw band runs on the wheel rim** – The saw band and wheel rim can be damaged
1. Start and stop saw band drive.
  2. Stop the main switch!
  3. Open rear cover of the saw frame.



4. Check saw band placing on the wheels.
- If the distance of the rear part of the saw band from wheel rim is 1 – 3 mm, setting is right.
  - If the distance is bigger than 3 mm, or the saw band runs on the wheel rim, saw band run must be set.

#### 4.4.2. Saw band setting



The saw band run is set with screw in the stretching cube on the saw frame. Optimal distance has been determined at **1 – 3 mm**.

- Turn by screw to the right, the saw band approximates to the stretching wheel rim.
- Turn by screw to the left, the saw band departs from the stretching wheel rim.

Check saw band run again after setting.

#### 4.5. Saw frame lower stop position adjustment

The lower stop limits the lowest position of the saw frame. This stop point has to be checked at least once a month. If the lower stop point is incorrectly adjusted, the cutting table can be damaged or the material will not be cut completely

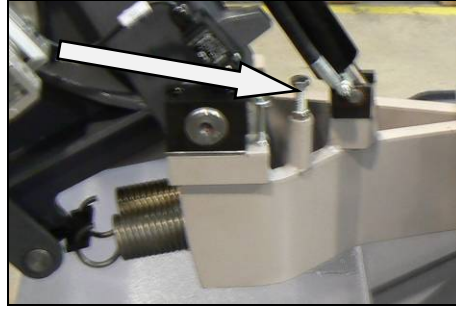

1. Lift the saw frame to the top position.
2. Release the nut of the screw and set it to the desired value.
3. Secure the screw with nut.
4. Set the limit switch of the saw frame lower position.

#### 4.6. Limit switch of the saw frame lower position adjustment

If the lower stop of the saw frame was set, the limit switch must be set again.

##### 4.6.1. Check setting

Lower the saw frame to the bottom position. If the saw frame is on the lower stop and the limit switch was responded, the limit switch adjustment is right. If the limit switch is not right, it must be set.

##### 4.6.2. Limit switch setting

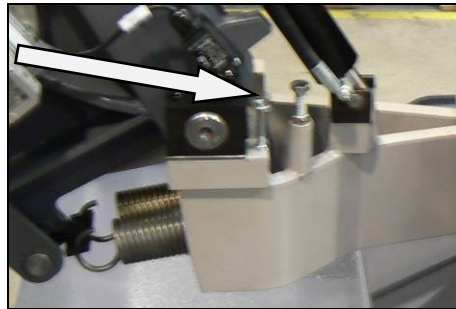

1. Release the nut of the stop screw of the switch and screw on the screw.
2. Lower the saw frame to the lower stop. Start the saw band drive.
3. Screw off the stop screw of the switch, until the saw band drive is not stopped.
4. Secure the screw with the nut and check limit switch adjustment again.

## 4.7. Cooling agents and chips disposal

The quality of the cooling agent will deteriorate due to:	If the solution is too weak:	If the solution is too strong:
<ul style="list-style-type: none"> <li>• use of contaminated water</li> <li>• impurity</li> <li>• outside oil contamination (hydraulics, gears)</li> <li>• high operating temperatures</li> <li>• lack of air circulation</li> <li>• wrong concentration</li> </ul>	<ul style="list-style-type: none"> <li>• corrosion protection is diminished</li> <li>• lubrication decreases</li> <li>• microbial attack is more likely</li> </ul>	<ul style="list-style-type: none"> <li>• the cooling ability is decreased</li> <li>• foam behaviour increases</li> <li>• emulsions stability deteriorates</li> <li>• sticky residue develops</li> </ul>

### 4.7.1. Coolant device inspection

The state of the cooling agent has significant influence on the cutting quality and on the operational life of the machine. Lifetime of the cooling liquid is 1 year, after this time we recommend change the cooling liquid. This time is dependent on the degree of pollution cooling liquid (especially with oils) and on the other factors.

**Check level of the cooling liquid and function of the pump periodically!**

**Note:**

*If the state of the cooling liquid is not satisfactory, the cooling liquid must be changed.*

Check the state of the cooling agent according to the following table:

Testing	Interval	Method	Condition	Precaution
Liquid level	daily	visually	too low	after concentration check, refill with water or emulsion
Concentration	daily	refractometer densimeter	too high too low	refill water refill base emulsion
Smell	daily	by sense of smell	unpleasant smell	good ventilation, add biocides or renew coolant
Contamination	daily	by sense of smell	visible oil leaks, sludge fungi	surface cleaning, fix leaks, add biocides or fungicides, or coolant renewal after added system cleanser*
Corrosion-protection	when necessary	visually chip test Herbert-test	insufficient corrosion protection	test stability, if necessary – increase concentration or pH value
Stability	when necessary	refractometer	oiling	add concentrate, enquiries to supplier
Foam reaction	when necessary	shaking test	too much foam, foam disperses too slowly	avoid aeration, increase water hardness, ix with defoamer

\* According to manufacturers' instructions

### 4.7.2. Chips disposal

Chips resulting from cutting operations must be disposed of in accordance with the relevant regulations.

- Let the chips drip excess fluid!
- Fill a watertight container with the chips! Be careful that the container does not leak, because even after a long dripping time, they still contain coolant residue.
- *Place the container into the care of a disposal company equipped for the disposal of chips contaminated with cooling liquid.* In case the machine is equipped with micro-spray installation, the chips must also be handed over to a disposal company.

## 4.8. Hydraulic, Greases and oils

### 4.8.1. Gearbox oils

In gearboxes, oil is used for the whole lifetime of the gearbox. We recommend replacing of the filling oil in case of repair.

Use oils with specification DIN 51517 in the gearboxes. Select the viscosity grade ISO VG according to the original oil fill.

**Attention:**

*When replacing, use oils recommended by BOMAR or oils, which has comparable parameters from the other manufacturers. Do not forget, that mineral and synthetic oils must not be mixed!*

#### Recommended oils and quantity according to the type of the band saw

Band saw	Gearbox oil	Capacity
Workline 410.280 RB	Shell Tivela S 320	1,0 l
Swarf conveyor	Shell Tivela S 320	0,075 l

#### Comparative table of the gearbox oils

Manufacturer	Viscosity grade		
	ISO VG 100	ISO VG 220	ISO VG 320
BP	Energol GR-XP 100	Energol GR-XP 220	Energol GR-XP 320
Castrol	Alpha SP 100 Alpha MW 100	Alpha SP 220 Alpha MW 220	
Elf	Reductelf SP 100	Reductelf SP 220 Reductelf Synthese 220	Reductelf SP 320
Esso	Spartan EP 100	Spartan EP 220	Spartan EP 320
Mobil	Mobilgear 627	Mobilgear SHC 220 Mobilgear 630	Mobilgear 632
ÖMV		PG 220	
Paramo	PP 7	Paramo CLP 220	Paramo CLP 320
Shell	Shell Omala 100	Shell Omala 220 Shell Tivela S 220	Shell Omala 320 Shell Tivela S 320
Total	Carter EP 100	Carter EP 220	Carter EP 320

### 4.8.2. Lubricant greases

We recommend using lithium based saponified grease, class NGLI-2 for lubrication. Different greases are mixable, if their oil bases and consistence type are identical.

#### Comparative table of the lubricant greases:

Manufacturer	Type of the lubricant grease
BP	Energrease LS - EP
DEA	Paragon EP1
Esso	FETT EGL 3144
	Beacon EP 1 Beacon EP 2
FINA	FINA LICAL M12
Klüber	Microlube GBO
	Staburags NBU8EP

Manufacturer	Type of the lubricant grease
	Isoflex Spezial
Optimol	Optimol Longtime PD 0, PD1, PD2
Shell Aseol AG	ASEOL Litea EP 806-077
Texaco	Multifak EP1

### 4.8.3. Lubrication

There are several places on the machine, which are necessary to grease periodically. It secures the right function of the machine.

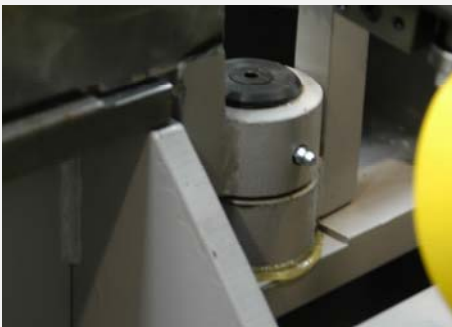
Lubrication place	Lubrication
	The guiding cubes leading – grease with oil from both sides once a week.
	

### 4.8.4. Hydraulic oils

Replace the hydraulic oil once in 2 years, because the oil can deteriorate its properties and cause problems the hydraulic equipment. If the hydraulic system is equipped with filter (2SF 56/48-0,063), replace the filter too.

Use oils with specification DIN 51524-HLP, ISO 6743-4 and viscosity grade ISO VG 46 in hydraulic aggregates. Hydraulic oils quantity – see chapter **Hydraulic oil level check**.

**Note:**

*When replacing, use oils recommended by BOMAR or oils, which has comparable parameters from the other manufacturers. Do not forget, that mineral and synthetic oils may not be mixed!*

**Comparative table of the hydraulic oils**

Manufacturer	Type	Manufacturer	Type
Agip	Oso 46	Ina	Hidraol 46 HD
Aral	Vitam GF 46	Klüber	Lamora HLP 46
Avia	Avilub RSL 46	Hungary	Hidrokomol P 46
Benzina	OH-HM 46	Mobil	Mobil DTE 25
BP	Energol HLP 46	ÖMV	HLP 46
Bulgaria	MX-M/46	Poland	Hydrol 30
Castrol	Hyspin AWS 46	Rumania	H 46 EP



Manufacturer	Type	Manufacturer	Type
Čepro	Mogul HM 46	Russia	IGP 30
DEA	Astron HLP 4hy6	Shell	Tellus Oil 46
Elf	Elfolna 46	Sun	Sunvis 846 WR
Esso	Nuto H 46	Texaco	Rando HD B 46
Fam	HD 5040	Valvoline	Ultramax AW 46
Fina	Hydran 46		

#### 4.8.5. Hydraulic unit service

After 50 hours working time, or the latest 3 month after the first run, the first service should be carried out. This includes:



- checking off all screws and connections, fixing points, tubes and hoses for leakage
- Cheb hydraulic oil level
- During time of duty the oil temperature shouldn't exceed 60-70°C
- check function of signaling components (thermometer, level gauge, dirty filter indicator)
- Check the adjustment of working pressure

**To realise a high reliability of the power pack, the manufacturer lays down following inspection intervals**

Interval	daily	weekly	monthly	three monthly	six monthly	annually
<b>Hydraulic fluid</b>						
Level	-	•	-	-	-	-
Temperature	-	•	-	-	-	-
Condition	-	-	•	-	-	-
Change interval	-	-	-	-	-	•
<b>Filter</b>						
Change interval	-	-	-	-	-	-
<b>Other checks</b>						
External Leakages	•	-	-	-	-	-
Contamination	•	-	-	-	-	-
Damages	•	•	-	-	-	-
Noise-(level)	•	-	-	-	-	-
Gauges	-	-	•	-	-	-

#### 4.9. Machine cleaning

Clean the machine from the cooling liquid and impurities after every shift stopping. Conserve the guiding surfaces, mainly.



- Clamping jaws guiding of the vice.
- The guiding of the feeder.
- Loading surface of the vice.

## 4.10. Worn pieces replacement

### 4.10.1. Hard metal guides replacement

If the hard metal guides cannot be adjusted, they have to be replaced.

1. Dismantle the saw band. Remove the hosepipe leading the cooling agent. Dismantle guide cube of the saw band.



2. Loosen the adjusting screws of the metal guide.



3. Loosen the binding screw of first metal guide. Remove adjustable hard metal guide.



4. Loosen the binding screw of second metal guide. Remove the hard metal guide
5. Insert new hard metal guides and fasten them tightly.
6. Mount the saw band. Adjust the hard metal guides.

### 4.10.2. Round brush replacement

If the chip removing brush is so worn, that it does not fulfil its function, the brush must be replaced.



1. Release the nut of the brush, exchange old brush to new brush and screw on the nut of the brush.
2. Set the brush to the saw band.

#### 4.10.3. Saw band guiding rollers replacement

If the saw band is not sufficiently guided by guiding pulleys or if the pulleys are obviously worn, the pulleys should be replaced.

**ATTENTION!**

*Guiding pulleys must be replaced together on both guiding cubes!!*

1. Dismantle the saw band.
2. Disconnect the hose from the cooling agent, screw off the pressure regulation. Let the pressure regulation connected to the hydraulic system. Dismantle the guiding cube of the saw band..

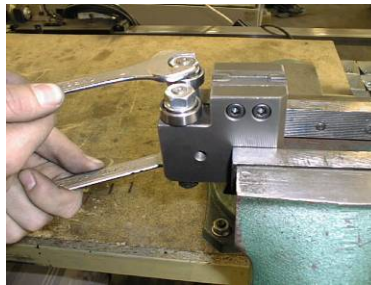

3. Tighten the guiding cube to the vice and dismantle both eccentrics with bearings following way.

**ATTENTION!**

*Mark both eccentrics placing and components on the eccentric!  
 Eccentrics must not be replaced with each other!!*

4. Screw off nuts from eccentrics..



5. Remove eccentrics from bearings by means of the swager



6. Change all bearings and other worn parts.



7. Install eccentrics to the cubes. Install components on both eccentrics in given order. Put bearings by means of the preparation on eccentrics.

**ATTENTION!**

*Do not replace the eccentrics placing in the cube*



8. Screw on nuts on both eccentrics and tighten them.



9. Insert the saw band to the guiding cube (ca. 15 – 20 cm). Set the eccentrics by means of the wrenches, the saw band must run in the centre. Guide pulleys must not press too much on the band, but must spin freely during the band run.
10. Tighten nuts on both eccentrics.
11. Remove the testing piece of saw band from the cube lead. Install the guiding cube on the machine and connect the pressure regulation to the cut and cooling. Install the saw band.

#### 4.10.4. Stretching wheel replacement

1. Dismantle the saw band.

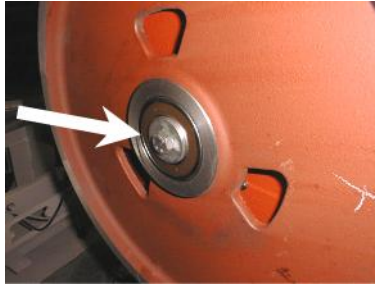

2. Screw off the screw and take down the washer.

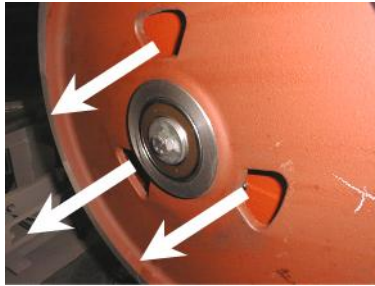

3. Pull off the wheel from the shaft by means of the three-armed puller. If bearing stayed on the shaft, pull off it too
4. Check score of the bearings of the stretching wheel and replace them for new.

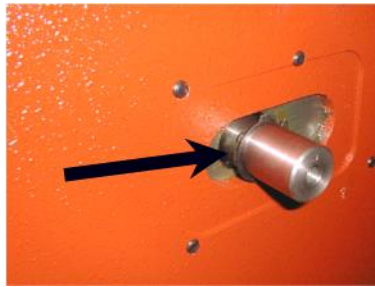

5. Clean the shaft and grease it with oil. Insert retaining ring to the groove.

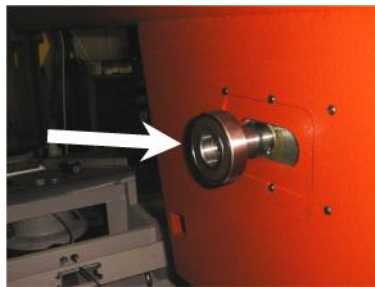

6. Install bearing on the shaft and move it to the retaining ring. Insert the distance ring on the shaft and move it to the bearing.



7. Insert the retaining ring to the hole in the wheel.



8. Insert the bearing to the hole in the wheel and press it to the retaining ring.



9. Put the wheel on the shaft and screw on the preparation to the wheel stretching to the hole in the shaft.



10. Pull on the wheel on the shaft.



11. Screw on washer and screw back.
12. Install the saw band. Wheel replacement is ready.

#### 4.10.5. Driving wheel replacement

1. Dismantle the saw band



2. Screw off the screw and remove the washer.



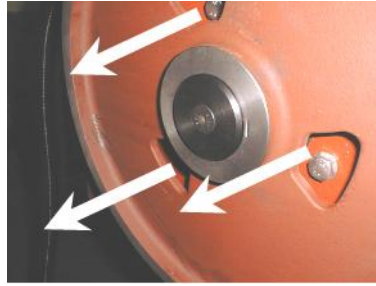

3. Pull off the wheel from the shaft by means of the three-armed puller.

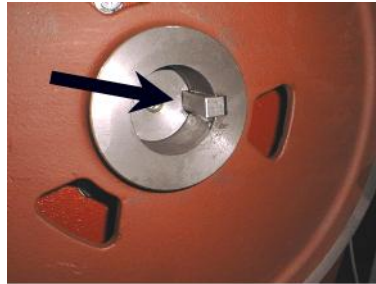

4. Install the wheel on the shaft. Insert the feather to the groove.



5. Screw on the preparation to the wheel stretching to the hole in the shaft. Pull on the wheel on the shaft.



6. Screw on washer and screw back.
7. Install the saw band. Wheel replacement is ready.

#### 4.10.6. Cooling liquid pump replacement

**Only a qualified worker can carry out the connection!**

**High-voltage shock may have fatal results**

1. Pull the tank with the liquid from the pedestal.
2. Remove the hosepipe leading to the cooling agent from the plug on the pump. Screw off four screws from the cooling pump flange and pull out the pump from the sheet metal holder.



3. Remove the cover of the pump terminal switchboard. Disconnect 4 terminal connectors of the input cables. Cables are identified according to the red clamps..



4. Loosen the bushing and pull the cable out from the pump.

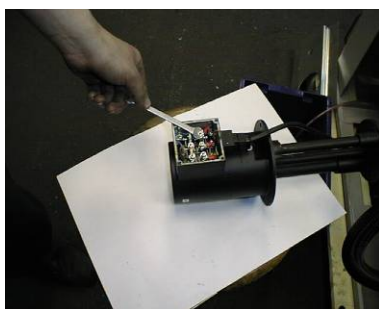

5. Dismantle new pump switchboard cover. Push the cable through the bushing and fasten it.



6. Screw on the cable bushing and cover of the terminal block. Do not forget the rubber gasket! Tighten the cooling liquid hose with non-stick tape and screw it again. Install cooling liquid hose, place the pump on the sheet metal holder and screw it





## 5. **Závady / Troubleshooting**

## 5.1. Mechanical problems

Problem	Possible causes	Repair
1. Slanting cut	- Wrongly adjusted hard metal guides.	Set according to the chapter „Servicing and adjustment“
	- Worn hard metal guides.	Replace to the chapter „Worn pieces replacement“
	- Wrongly adjusted cubes of the saw band guiding.	Set according to the chapter „Servicing and adjustment“
	- Worn bearings of the saw band guiding.	Replace according to the chapter „Worn pieces replacement“
	- Wrongly adjusted swarf brush.	Set according to the chapter „Servicing and adjustment“
	- Worn swarf brush.	Replace according to the chapter „Worn pieces replacement“
	- Insufficient saw band stretching.	Rise the saw band stretching and set the limit switch.
	- Wrongly chosen tooth system of the saw band.	Replace the saw band and keep the instructions of manufacturer on new saw band choice.
	- Worn saw band.	Replace the saw band.
	- Wrongly balanced roller conveyor.	Set the roller conveyor.
	- Dirty feeding board.	Cleanse the feeding board from debris, chip and residue material.
	- Guiding arm and guiding cube are loosened.	Clamp the guiding arm.
	- Guiding arm and cube are too far from the material.	Set the guiding cube to the material.
- Too fast cutting rate.	Lower the material feeding speed.	
- Unexpected oscillation in material quality.	Set the cut and feeding speed to the relevant material.	
2. The cut is not cut upon desired angle	- Securing lever is loosened.	Check the securing lever efficiency and carry out its adjustment according to chapter „Servicing and adjustment“.
	- Set angle does not match the cut angle.	Check the angle adjustment with a protractor and possibly set it according to chapter „Servicing and adjustment“.
	- Insufficient saw band stretching.	Stretch the saw band and set the limit switch according to chapter „Servicing and adjustment“.
	- Guiding arm and guiding cube are loosened.	Fasten the guiding arm and the cube.
	- Dirt between material and clamping jaw.	Cleanse the material and mating jaw.
3. Short lifetime of the saw band	- Insufficient saw band stretching.	Raise the tightening of the saw band set the scanner of saw band tightening according to chapter „Servicing and adjustment“.
	- Worn swarf brush.	Check the swarf brush condition and replace it in case of excessive use as described in chapter „Worn pieces replacement“
	- Wrongly adjusted swarf brush.	Check swarf brush adjustment, set it according to chapter „Servicing and adjustment“
	- Over stretched saw band	Lower stretching of the saw band and set the limit switch of the saw band stretching according to chapter „Servicing and adjustment“
	- Wrongly adjusted hard metal guides.	Check the adjustment of the hard metal guides and carry out adjustment as described in chapter „Servicing and adjustment“
	- Worn hard metal guides of the saw band.	Check the condition of the hard metal guide and if it is too worn, replace hard metal guides according to chapter „Worn pieces replacement“

Problem	Possible causes	Repair
	- Worn saw band guide bearings.	Check guiding bearings and if you notice some sort of excessive damage, replace them according to chapter „Worn pieces replacement“
	- Wrongly adjusted guiding cubes of the saw band.	Set guiding cube according to chapter „Servicing and adjustment“
	- Wrongly adjusted down feed and saw band speed.	Adjust the feeding and speed of a saw band according to values published by saw band manufacturer.
	- Different material quality.	Adjust feeding and speed of a saw band according to desired material (try cut-test).
	- Low-class saw band	Replace the saw band (contact your local accessory supplier for more information)
	- Wrongly chosen saw band tooth system.	Replace the saw band and keep instructions of the manufacturer on the choice.
	- Wrongly adjusted tracking.	Check the space between top of a saw band and driving wheel. Perhaps adjust the tracking as described in chapter „Servicing and adjustment“
4. Insufficient cut output.	- Worn saw band.	Replace the saw band and keep instructions of the manufacturer on the choice.
	- Wrong saw band tooth system.	Replace the saw band and keep instructions of the manufacturer on the choice.
	- Wrongly set down feed and speed of a saw band.	Set feed and speed of a saw band according to values published by saw band manufacturer.
5. The cut is not finished.	- Wrongly adjusted lower stop point of the saw frame.	Check lower limit switch and screw.
	- Stop point surface is messed-up.	Cleanse stop point surface of the limit switch from debris and residue material.
6. By choke is not possible turn	- Metal clamps between valve and panel.	Clamps must be removed and put on the shaft O-Ring about 10x2 mm.
	- Metal clams are in body of valve.	Valve must be cleared or changed.
7. Saw band drive cannot be started.	- Pressure switch is adjusted wrong.	Set the pressure switch according to chapter „Servicing and adjustment“
	- Pressure switch is defective.	Replace defective parts of the pressure switch.
8. The saw bands are cracked.	- In stretching wheel is wrong adjusting geometry.	Adjust distance band from recess wheel c.2 mm according to operating instructions.
	- Hard metal plates of circuit saw band are not adjusting.	Hard metal plates of circuit saw band must be adjusting according to operating instructions.
	- Guiding cubes are not adjusting (bearings + hard metal circuit)	Guiding cubes must be adjusting (bearings + hard metal circuit) according to operating instructions.
	- Bearings of guiding cubes are used (rolling elements are damaged or outside ring of bearing has conical form).	Bearings of guiding cubes must be replaced. Bearings must be adjusting according to operating instructions.
9. Damage tooth system of the saw band	- In gripping the lifting cylinder is backlash.	
	- Squeezed pin upper or downer holder of the lifting cylinder.	Exchange complete upper or downer holder of lifting cylinder.
10. The saw is cut downing.	- Geometry of hardmetal guiding cubes is wrong adjusted.	Hardmetal guiding cubes must be adjusted.
	- Bearings of guiding cubes are used.	Bearings of guiding cubes must be replaced.
11. Cleansing of the saw band is not functional.	- Elastic wheel of the brush drive is worn-down.	Elastic wheel of the brush must be changed.
	- Knurling of the driving wheel is worn-down.	Driving wheel must be changed.
	- The shaft of the brush drive is rusted.	The shaft of the brush must be cleaned and oiled.

Problem	Possible causes	Repair
	- The brush position and the brush cover is adjusted wrong – with the brush cannot be turned.	The brush cover must be posed, in order to the brush can be turned.
12. The saw arm periodically rise and fall during the cut; this cause short lifetime of the saw band.	- Backlash in driving wheel lodgement on the shaft.	Change the driving shaft for a long one, new bearings, distance ring, new driving wheel, spring, two covers on the forehead of the shaft + screws.
	- Worn channel for spring.	

## 5.2. Electric and hydraulic problems

Problem	Possible causes	Repair
1. Machine is not possible start.	- In socket is not voltage	Line voltage must be checked.
	- Transfer relay is closed (thermal protector)	Each FA relay must be checked.
	- Limit switch of saw band stretching, cover of frame or cover of saw band is not started.	Check of saw band stretching and covers closing.
2. When cut is finished, the frame is not raising.	- Bottom limit switch is adjusted wrong.	Bottom limit switch must be adjusted according to chapter ADJUSTING.
	- In hydraulic (pneumatic) ring is error. HYTOS (BOSCH) is not acting to frame uplift.	Function of magnetic valve must be checked, valve must be closed, voltage of clamps and inductor must be checked.
3. Electric motor and pump are without voltage. Between contactor and thermal protector is not voltage.	- Wrong contactor.	Replace contactor of engine.
4. The indicator of speed saw band is not functional.	- Sensor of speed is not adjusted.	Sensor of speed must be adjusted.
	- Defective display	The display must be changed.
	- Wrong sensor – diode of indicator speed is not light.	Sensor must be changed and adjusted.
5. Protector is switched off from engine hydraulic aggregate MA3 sometimes.	- Into hydraulic system is high working pressure.	Service engineer must reduce the pressure in hydraulic system.
6. The hydraulic aggregate cannot be started	Auxiliary contact on thermo-relay FA1 is defective.	Replace the defective contact on motor starter FA1.
7. Hydraulic aggregate is switched on but the saw arm or the main vice is not functional	- Wrong connection of electrical supply. The electrical phases are connected conversely.	The phases must be switched. Only service engineer can do this.
8. Cooling is not active	Lack of cooling agent.	Fill the tank with cooling agent.
	- Thermal relay is defective	Change the thermal relay
	- Input hosepipe is broken or obstructed.	Check the cooling circuit and perhaps cleanse cooling system.
	- Cooling pump protection is defective	Check the protection of cooling pump if need change it.
	- Cooling pump is defective.	Replace the cooling pump.

### 5.3. Hydraulic problems

Problem	Possible causes	Repair
1. Hydrogenerator not supplying oil	• reverse rotation	Check the connections of each phase. Reconnect properly connection of the electrical phases.
	• shortage of oil in the tank	Add hydraulic oil
	• Oil viscosity does not correspond prescribed viscosity value	Change hydraulic oil.
	• Hydrogenerator malfunction	Call service
	• Wrong power supply connection.	Check the connections of each phase. Reconnect properly connection of the electrical phases.
2. Hydraulic oil contains bubbles	• Hydraulic circuit is not adequately deaerated	Make deaeration of hydraulic circuit.
	• Low oil level	Add hydraulic oil
	• the pump shaft seals damaged	Call service
3. Increased mechanical noise	• damaged joint drive	Call service
	• damaged or destroyed motor bearings	Call service
	• air intake	Check for leaks.
4. Low pressure, pump supplies oil	• problem in the safety valve	Wrong settings. Check the settings and adjust the safety valve.
	• pump wear	Call service
	• external or internal leakage	Call service
5. Hydrogenerator is seized	• damage by solid particles in oil	Make oil filtration, or call the service.
	• non-prescribed oil	Change hydraulic oil.
	• wrong type of oil	Change hydraulic oil.
	• exceeding the life of the pump	Call service
6. Overheating oil	• cooler malfunction	Check the cooler function or call service.
	• wear the pump, the energy is converted into heat	Call service
7. Hydraulic valve can not be readjusted	• electromagnet has no signal (voltage) - interrupted supply lines	Check again.
	• Electromagnet coil burnt	Replace coil – Call service.
	• spool valve sticking	Replace valve – Call service



## 6. **Schémata / Schemas / Schematics**

6.1. Elektrické schéma /  
 Elektroschema /  
 Wiring diagrams – 3×400 V, TN-C-S

Schéματα  
 Schemas  
 Schematics

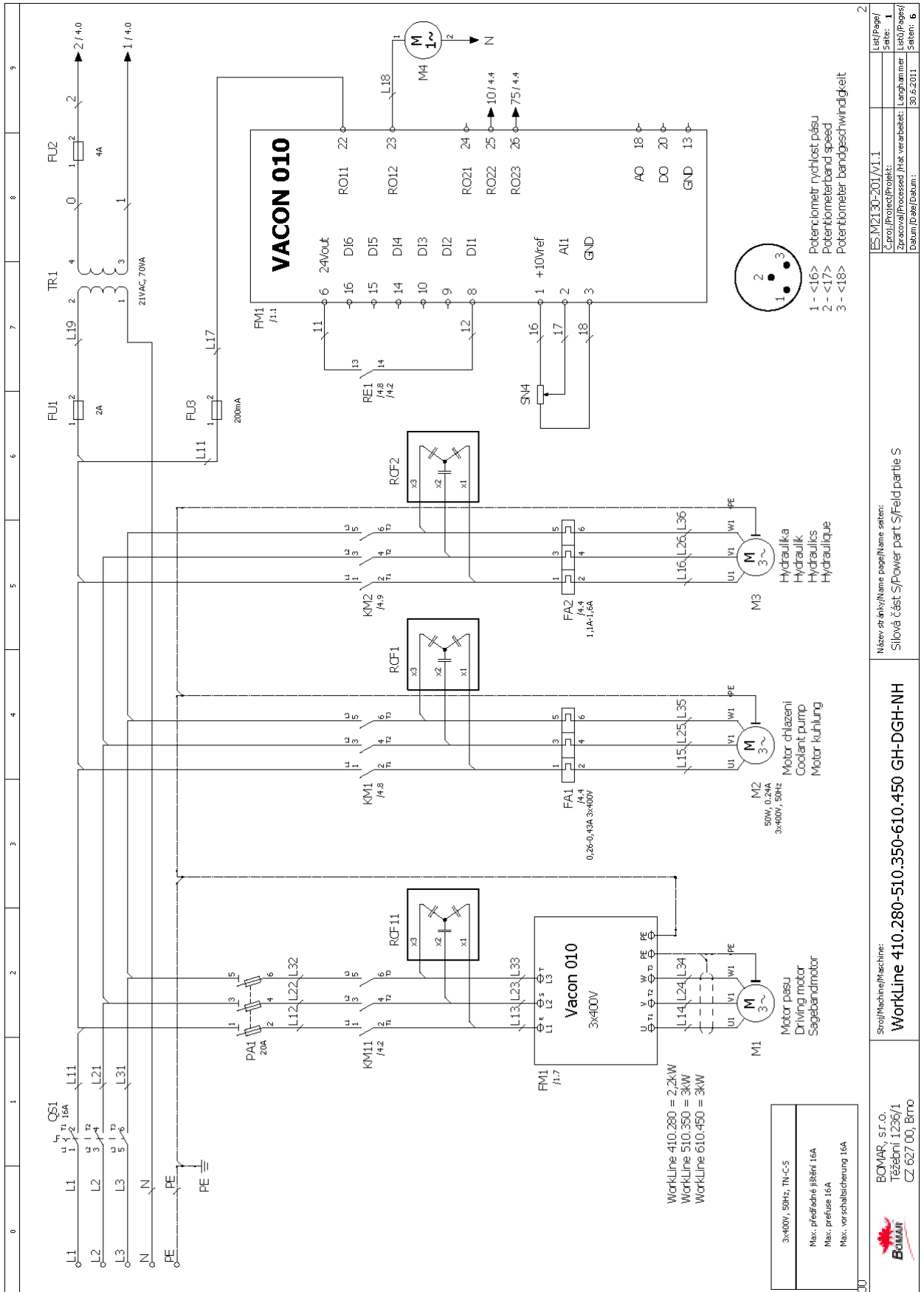

00	0	1	2	3	4	5	6	7	8	9
Název stránky/Name page/Name sheet: SI/DVá část S/Power part S/Feld partie S Stroj/Machine/Maschine: <b>Workline 410.280-510.350-610.450 GH-DGH-NH</b> ES M2130-201/VI.1 Cípol/Project/Projekt: Zpracoval/Processed /Hat. verarbeitet: Langhammer Datum /Date/ Datum: 30.6.2011.										
										2
										1
										6



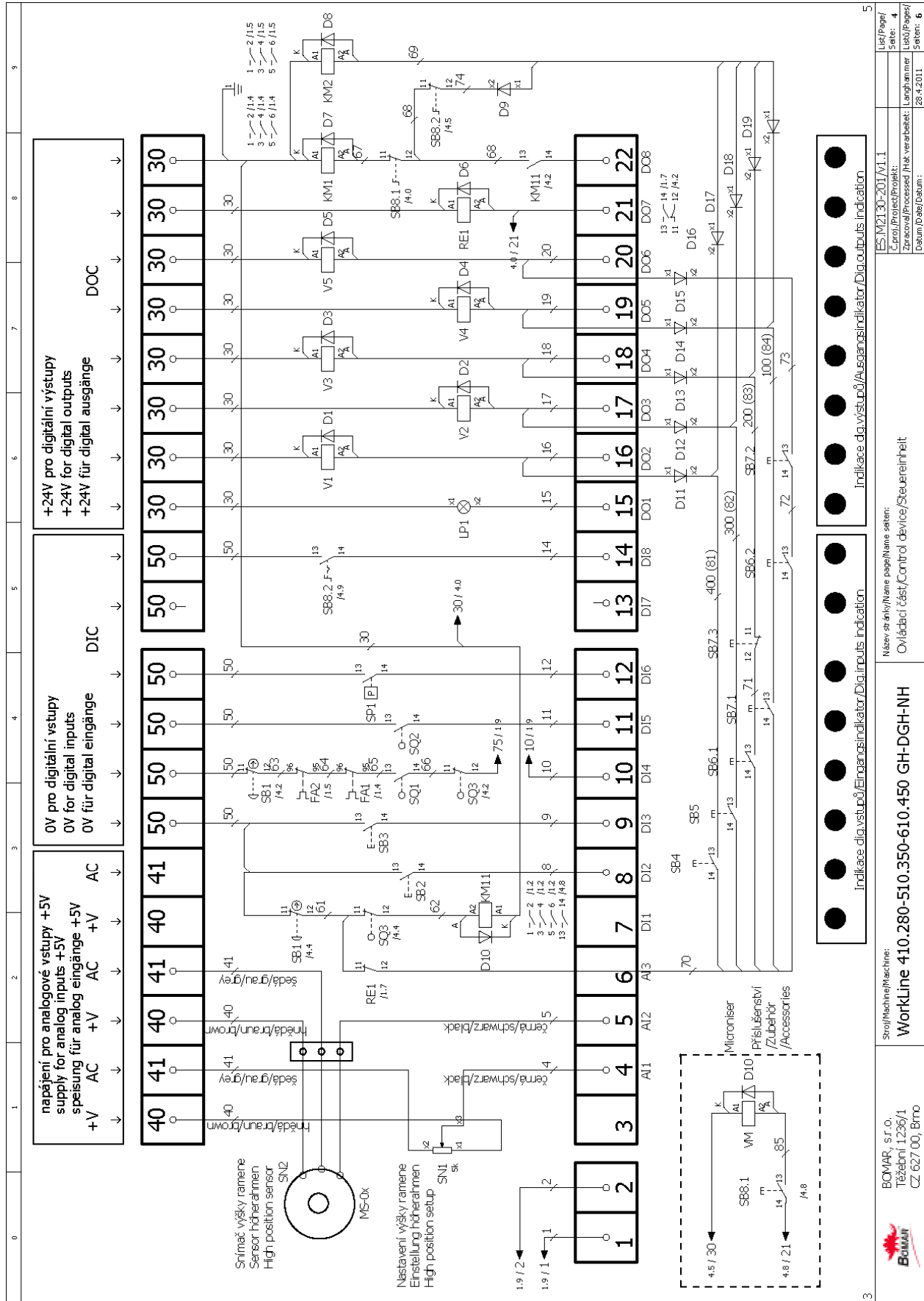

BOMAR, s.r.o. Těžební 1236/1 CZ 627 00, Brno		Srovnání/Machine/Model: <b>WorkLine 410.280-510.350-610.450 GH-DGH-NH</b>		Název stránky/název stránky/název stránky: Ovládací část/Control device/Steuerinheit		ES M2130-201/M1.1	
List/Page/		List/Page/		List/Page/		List/Page/	
Seite: 4		Seite: 4		Seite: 4		Seite: 4	
Zpracováno/Processed/		Zpracováno/Processed/		Zpracováno/Processed/		Zpracováno/Processed/	
Langbanmer		Langbanmer		Langbanmer		Langbanmer	
Seite: 6		Seite: 6		Seite: 6		Seite: 6	
Datum/Date/		Datum/Date/		Datum/Date/		Datum/Date/	
28.4.2011		28.4.2011		28.4.2011		28.4.2011	

Schemata  
Schemas  
Schematics

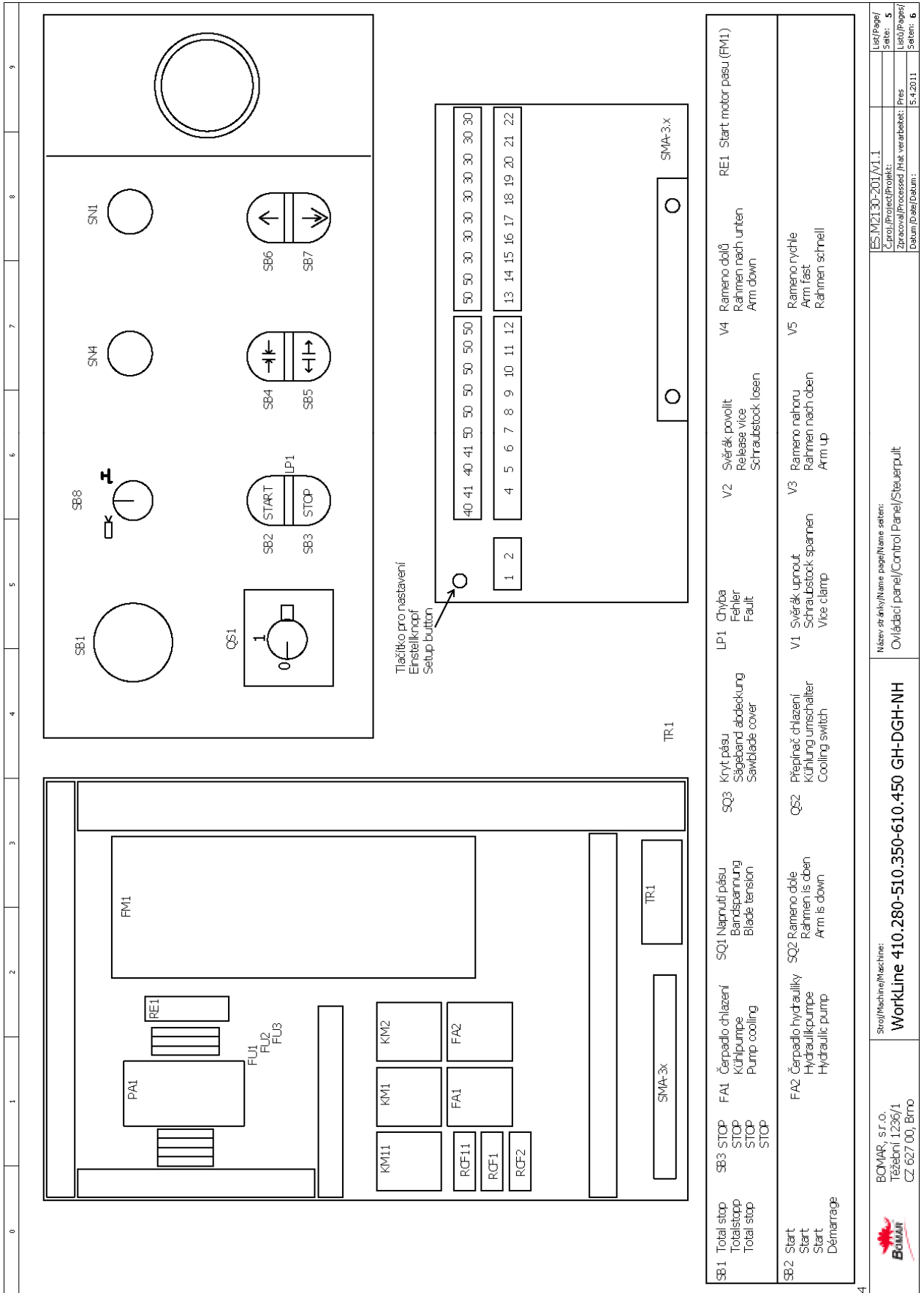

SB1	Total stop	SB3	STOP	FA1	Čerpadlo chlazení	SQ1	Napnutí pásu	LP1	Chyba	V2	Světlák povolit	V4	Rameno dolů	RE1	Start motor pásu (FM1)
	Total stop		STOP		Kühlpumpe		Bandspannung		Fehler		Release vice		Rahmen nach unten		
	Total stop		STOP		Pump cooling		Blade tension		Sawblade cover		Schraubstock lösen		Arm down		
SB2	Start	FA2	Čerpadlo hydrauliky	SQ2	Rameno dole	Q52	Přepínač chlazení	V1	Světlák upnout	V3	Rameno nahoru	V5	Rameno rychle		
	Start		Hydraulikpumpe		Rahmen is oben		Kühlung umschalter		Schraubstock spannen		Rahmen nach oben		Arm fast		
	Démarrage		Hydraulic pump		Arm is down		Cooling switch		Vice clamp		Arm up		Rahmen schnell		

		BOMAR, s.r.o. Trávní 1236/1 CZ 627 00, Brno		Strojí/Machine/Machine: <b>WorkLine 410.280-510.350-610.450 GH-DGH-NH</b>		Název stránky/Name page/Name sheet: Ovládací panel/Control Panel/Steuerpult		ES.M21.30-201/V1.1 Zpracováno/Processed/Prüf. verarbeitet: Pres. Datum/Dat./Datum: 5.4.2011		List/Page/ Strana/Seite: 5	
--	--	---	--	--	--	--	--	---	--	----------------------------------	--



## 6.2. Hydraulické schéma / Hydraulikschema / Hydraulic diagram

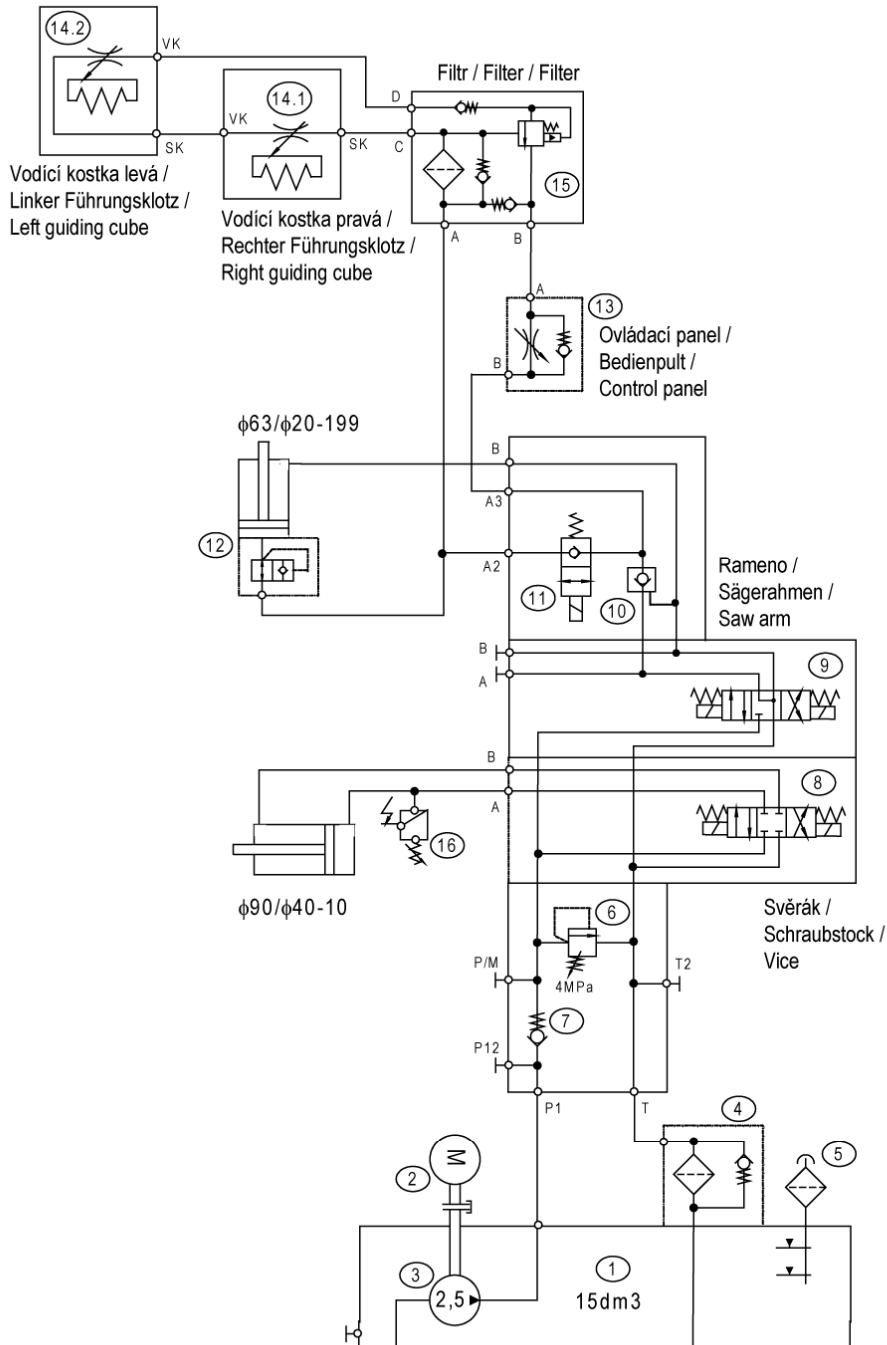

Základní technické parametry  
Technische Spezifikation  
Technical specification

Typ / Type / Type	Workline 280, 350, 450 NH/GH/DGH
Hydraulický agregát / Hydroaggregat	205.M216-100
Hydro aggregat	
Neuvedené světlosti / Unerwähnt Lichtbreite	JS6
Unlisted inside diameters	
Výstupní šroubení / Ausgangsschraubung	G1/4"
Output screwing	
$P_{max}$	4 Mpa
Q	3,3 dm <sup>3</sup> /min
n	1400 ot./min
P	0,25 kW

205.M216-100

WORKLINE 280 var.: NH / GH / DGH

WORKLINE 350 var.: NH / GH / DGH

WORKLINE 450 var.: NH / GH / DGH

Poz.	Název položky		ks
Pos.	Bezeichnung		Menge
Pos.	Item		Pcs.
1	Nádrž / Behälter / Tank	TM13,5/S 15 dm3	1
2	Elektromotor / Elektromotor / Electromotor	EM71 0,25kW/3B35 50 Hz, <1 A	1
3	Hydrogenerátor / Hydraulikgenerator / Hydrogenerator	10A2,5x053G 2,5 cm3/rmp	1
4	Ventil zpětný / Gegendruckventil / Clack-valve	MPF0301AG1	1
5	Nalévací zátka / Stopfen / Fill stopper	cPT-MD-FA/1	1
6	Přepouštěcí ventil / Bypašventil / By pass valve	SR1A-A/S10	1
7	Jednosměrný ventil / Einwegventil / One-way valve	SC1F-A2/H005	1
8	Rozváděč / Schaltschrank / Switchboard	RPEK1- 03G3Z11/02400E1K1	1
9	Rozváděč / Schaltschrank / Switchboard	RPEK1- 03G3Y11/02400E1K1	1
10	Hydraulický zámek / Hydraulisches Schloß / Hydraulic lock	RJV1-05-0	1
11	Rozváděč / Schaltschrank / Switchboard	SD3E-A2/S2L2+C13D- 02400E1K1	1
12	Pojistný ventil / Sicherungventil / Safety valve	VPNH ¼ 92.151.001	1
13	Škrtící ventil / Drosselventil / Throttle-valve	VS01-04/R2,5 92.152.001	1
14	Kostka regulace / Regulationklotz / Regulation cube	251.077	2/1
15	Block	92.153.005 729-0059	1/0
16	Tlakový spínač / Druckschalter / Pressure switch	0166415031059 20–50 bar	1



## **7. Výkresy sestav pro objednání náhradních dílů / Zeichnungen für Bestellung der Ersatzteile / Drawing assemblies for spare parts order**

- Při objednávání náhradních dílů vždy uvádějte: typ stroje (např. practix Workline 410.280 RB) , výrobní číslo (např. 125) a rok výroby (např. 1999).
- In die Bestellung der Ersatzteile führen Sie immer an: Maschinentyp (z. B. Workline 410.280 RB), Serien Nr. (z. B. 125) und Baujahr (z. B. 1999).
- For spare parts order, you must always to allege: type of machine (for example Workline 410.280 RB), serial number (for example 125, see cover page) and year of construction (for example 1999).

### 7.1. Workline 410.280 RB

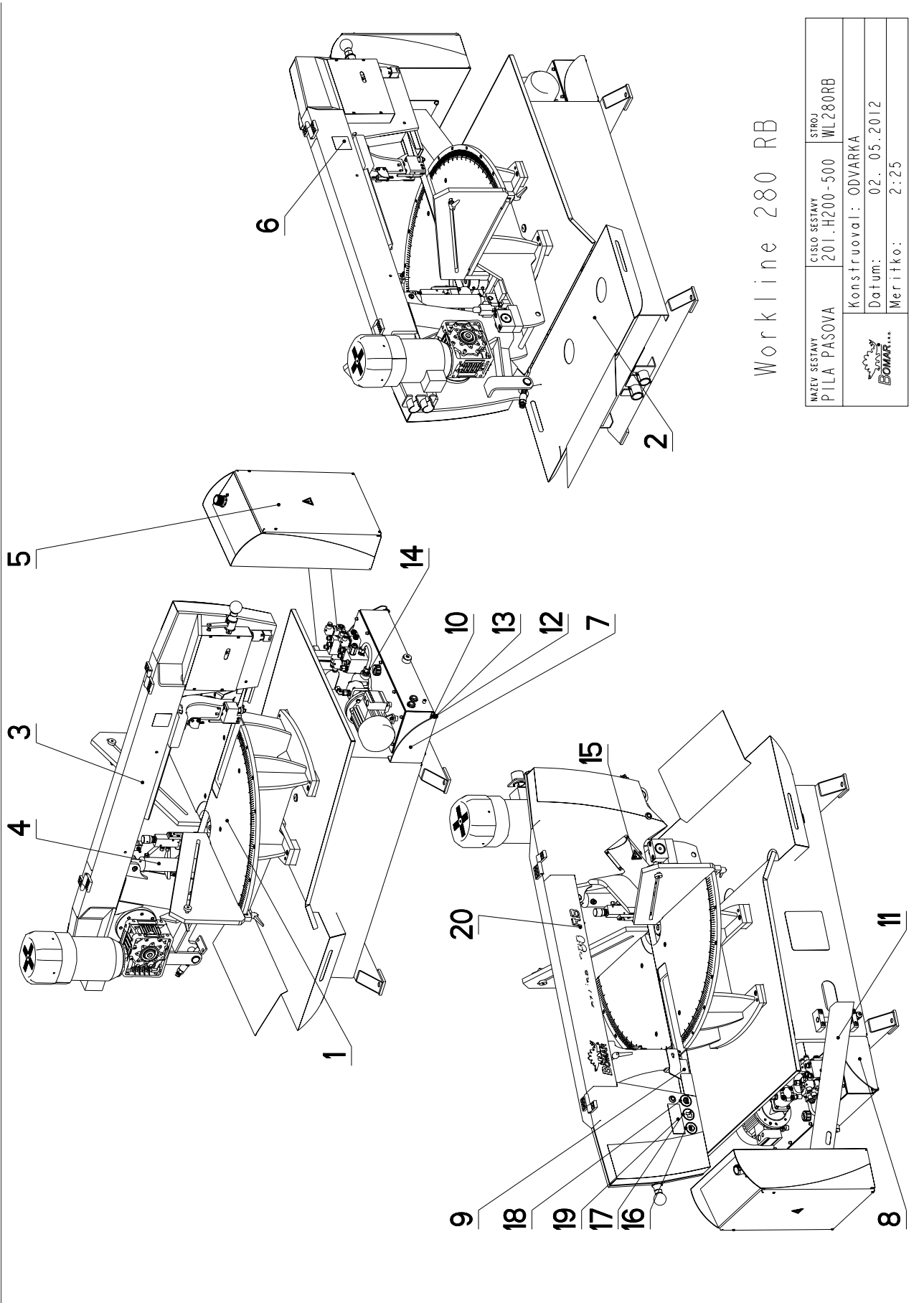

Workline 280 RB

NAZEV SESTAVY PILA PASOVA	CISLO SESTAVY 201.H200-500	STROJ WL280RB
Konstruoval: ODVARKA		
Datum: 02. 05. 2012		
Meritko: 2:25		



---

7.2. Kusovník / Stückliste / Piece list –  
Workline 410.280 RB

### 7.3. Rameno / Sägerahmen / Saw arm - 1

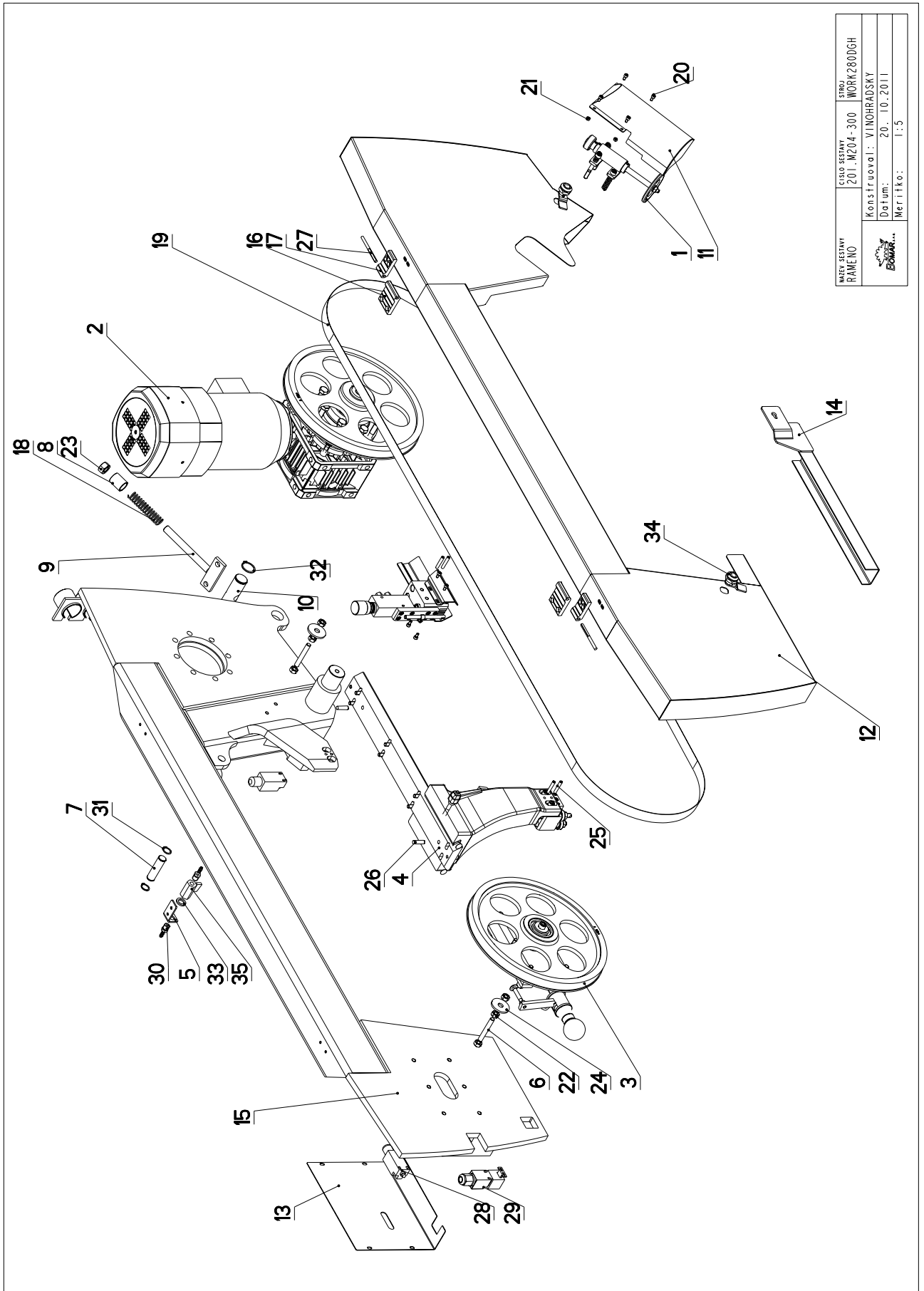

NAZEV SESTAVY RAMENO	ČÍSLO SESTAVY 201.M204-300	STROJ WORK280DGH
Konstruoval: VINOHRADSKY		
Datum: 20. 10. 2011		
Měřítko: 1:5		

## 7.4. Kusovník / Stückliste / Piece list – Rameno / Sägerahmen / Saw arm - 1

Cislo Sestavy 201.M204-300		Ver. 0		Nazev sestavy RAMENO/SAW ARM/SÄGERAHMEN		Ks	
Poz.	Objednací číslo	Ver.	Nazev položky	Rozměr			
1	201.8114-630	0	KARTAC / BRUSH / BURSTE				1
2	201.M205-000	0	PREVODOVKA / TRANSMISSION / GETRIEBE				1
3	201.M208-000	0	NAPINANI / TENSIONING / SPANNUNG				1
4	201.M210-150	2	VEDENÍ PASU / BELT GUIDE / SÄGEBANDFÜHRUNG				1
5	30.1814-011	1	DRŽAK / HOLDER / HALTER			P 3x76	1
6	30.3404-056	0	TYC ZAVIŤOVKA / THREADED POLE / GEWINDESTANGE			M10	2
7	30.6607-103	0	CEP / LUG / BOLZEN			TYC 18	1
8	30.9204-004	0	DISTANČNÍ / DISTANCE / DISTANZ			TR 26.9x2.65	1
9	30.LD04-005	0	DRŽAK / HOLDER / HALTER				1
10	30.M204-006	0	CEP / LUG / BOLZEN			d 30	1
11	30.M204-009	0	KRYT KARTACKU / BRUSH COVER / BÜRSTENABDECKUNG				1
12	30.M204-011	1	KRYT / COVER / ABDECKUNG				1
13	30.M204-012	0	KRYT NAPINANI / TENSIONING COVER / BANDSPANNUNGSABDECKUNG			P 1.5x280	1
14	30.M204-016	0	KRYT PASU / BELT COVER / BANDABDECKUNG				1
15	30.M204-201	0	RAMENO / SAW ARM / SÄGERAHMEN				1
16	30.R304-006	2	PANT / BOARD / PLATTE			PROFIL	2
17	30.R304-007	1	PANT / BOARD / PLATTE			PROFIL	2
18	31.9204-003	0	PRUŽINA / SPRING / FEDER			d2	1
19	44.103.002	0	PAS PÍLOVY 260 / SAW BELT / SÄGEBAND			3800x25(7)x0.90	1
20	90.001.25.007	0	SROUB IMBUS CERNÝ / ALLEN HEAD BOLT / IMBUSSCHRAUBE			M5X10	8
21	90.100.55.003	0	MATICE / NUT / MUTTER			MATICE _ M5	4
22	90.100.55.006	0	MATICE / NUT / MUTTER			MATICE _ M10	6
23	90.100.55.008	0	MATICE / NUT / MUTTER			MATICE _ M16	1
24	90.151.50.002	0	PODLOŽKA / WASHER / UNTERLEGSCHLEIBE			PODLOŽKA 12	2
25	90.302.02.001	0	KUZEL. KOLIK S ZAV. / TAPER PIN + THREAD / KEGELBOLZEN + GEWINDE			KOLIK 6X36	4
26	90.302.02.002	0	KUZEL. KOLIK S ZAV. / TAPER PIN + THREAD / KEGELBOLZEN + GEWINDE			KOLIK 8X30	2
27	90.307.02.001	0	KOLIK / PIN / BOLZEN			D6	2
28	91.173.007	0	SPINAC KONCOVÝ / END SWITCH / ENDSCHALTER			-R1WK	2
29	91.173.012	0	SPINAC KONCOVÝ / END SWITCH / ENDSCHALTER				1
30	94.202.002	0	REDUKCE / REDUCTION / ADAPTOR / REDUKTION			REDUKCE 6/R1/4"	2
31	95.800.008	0	SEGR HRIDEL. / OUTSIDE SAFETY RING / SICHERUNGSRING AUBEN			POJISTINY KROUZEK 18	2
32	95.800.013	0	SEGR HRIDEL. / OUTSIDE SAFETY RING / SICHERUNGSRING AUBEN			POJISTINY KROUZEK 30	2

Cislo Sestavy/Number of assembly/Nummer der Baugruppe; Verze (Ver.)/Version/Version; Nazev sestavy/Assembly title/Name der Baugruppe; Pozice (Poz.)/Position/Position;  
Objednací číslo/Purchase order number/Bestellnummer; Nazev položky/Volume title/Name der Position; Rozměr/Stock size/Abmessung

### 7.5. Rameno / Sägerahmen / Saw arm - 2

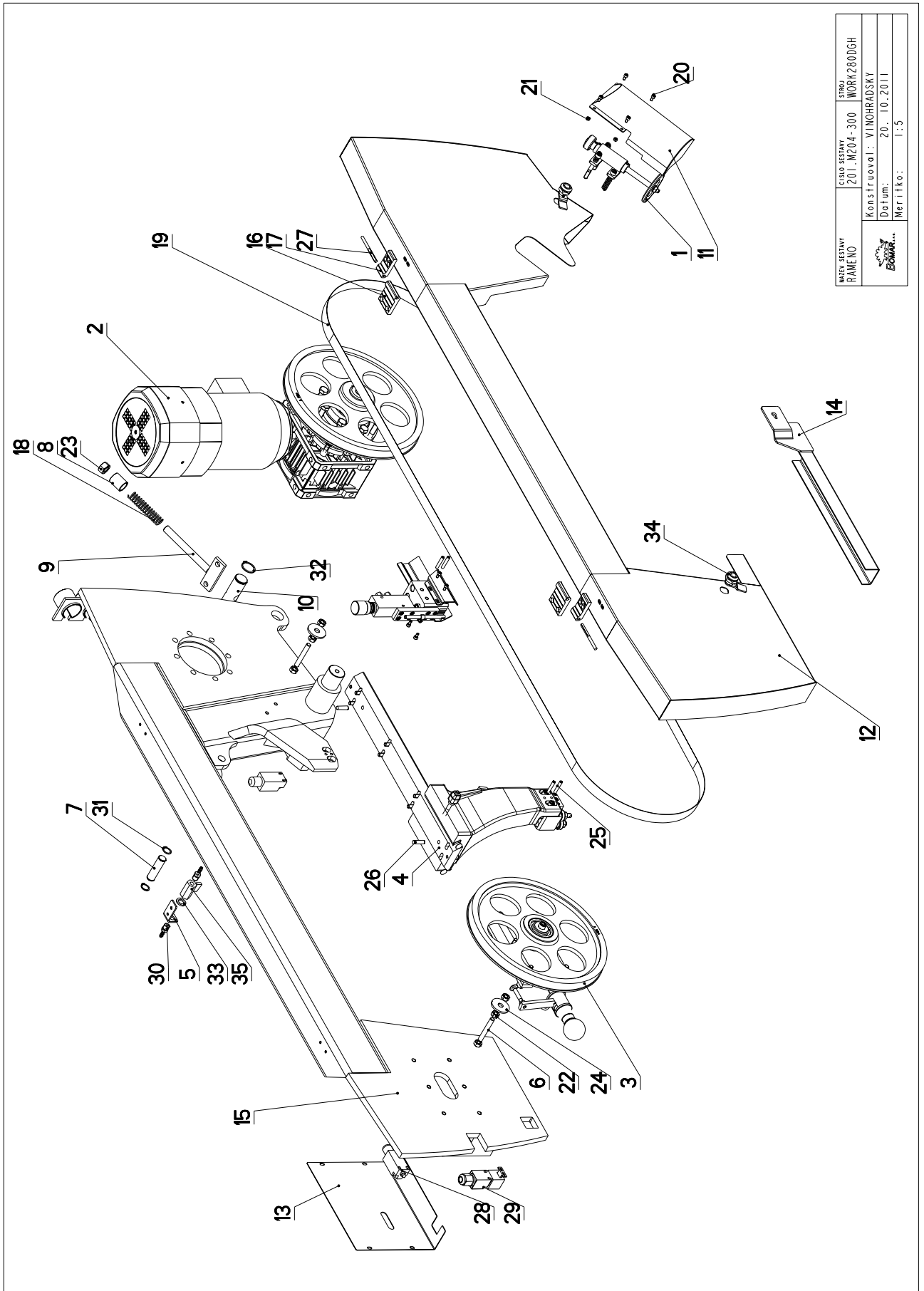

NAZEV SESTAVY RAMENO	ČÍSLO SESTAVY 201.M204-300	STROJ WORK280DGH
Konstruoval: VINOHRADSKY		
Datum: 20. 10. 2011		
Měřičko: 1:5		

**7.6. Kusovník / Stückliste / Piece list –  
Rameno / Sägerahmen / Saw arm - 2**

33	96.081.001	0	KROUZEK TESNICI / SEAL RING / DICHTUNGSRING	23x15x3	1
34	99.104.002	0	ZAMEK / LOCK / SCHLOSS	ZAMEK CINSKY	2
35	99.260.003	0	VENTIL / VALVE / VENTIL	1/4"	1

Cislo Sestavy/Number of assembly/Nummer der Baugruppe; Verze (Ver.)/Version/Version; Nazev sestavy/Assembly title/Name der Baugruppe; Pozice (Poz.)/Position/Position;  
Objednaci cislo/Purchase order number/Bestellnummer; Nazev polozky/Volume title/Name der Position; Rozmer/Stock size/Abmessung

## 7.7. Napínání / Spannung / Tensioning

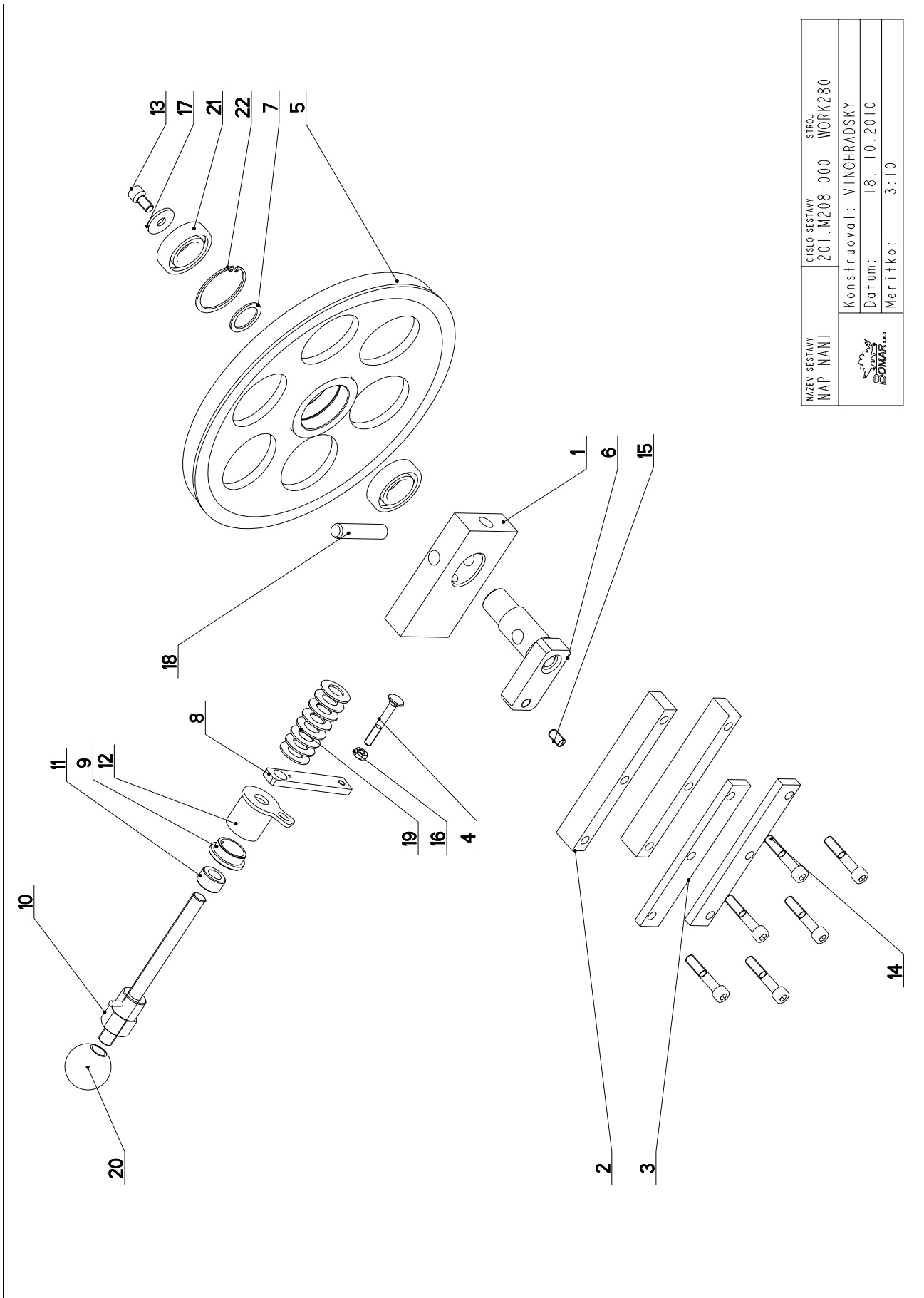

NAZEV SESTAVY NAPÍNÁNÍ	CÍSLO SESTAVY 201.M208-000	STROJ WORK280
		
Konstruoval: VINOHRADSKÝ		
Datum: 18. 10. 2010		
Meritko: 3:10		

## 7.8. Kusovník / Stückliste / Piece list – Napínání / Spannung / Tensioning

Císlo Sestavy 201.M208-000		Ver. 0		Název sestavy NAPÍNÁNÍ / TENSIONING / SPANNUNG			
Poz.	Objednací číslo	Ver.	Název položky	Rozměr	Ks		
1	30.0808-001	1	KOSTKA NAPÍNÁNÍ / TENSIONING CUBE / BANDSPANNUNGSWÜRFEL	80x30	1		
2	30.0808-002	1	LISTA VODICÍ / LEAD TRIM / FÜHRUNGSLEISTE	30x20	2		
3	30.0808-006	1	LISTA / TRIM / LEISTE	HR 30x10	2		
4	30.0808-007	0	SROUB / BOLT / SCHRAUBE	M8x60	1		
5	30.1708-001	1	KOLO / WHEEL / UMLENKRAD	ODLITEK	1		
6	30.1708-002	1	CEP NAPÍNÁNÍ / TENSIONING LUG / SPANNUNGSBOLZEN		1		
7	30.1708-003	0	PODLOŽKA / WASHER / UNTERLEGSCHLEIBE	d 40	1		
8	30.1708-004	3	DRŽÁK / HOLDER / HALTER	HR 20x8	1		
9	30.3508-004	0	KROUZEK / RING / RING	ø42	1		
10	30.4108-001	1	SROUB / BOLT / SCHRAUBE		1		
11	30.4108-002	0	DISTANC / DISTANCE / DISTANZ	TR 28x6	1		
12	30.6908-102	1	DRŽÁK / HOLDER / HALTER		1		
13	90.001.25.046	0	SROUB IMBUS / ALLEN HEAD BOLT / IMBUSSCHRAUBE	M10X20	1		
14	90.001.25.053	0	SROUB IMBUS / ALLEN HEAD BOLT / IMBUSSCHRAUBE	M10X55	6		
15	90.002.20.015	0	SROUB STAVEČÍ / ADJUSTMENT BOLT / STELLSCHRAUBE	SROUB M10X20	1		
16	90.100.55.005	0	MATICE / NUT / MUTTER	MATICE - M8	1		
17	90.151.50.001	0	PODLOŽKA / WASHER / UNTERLEGSCHLEIBE	PODLOŽKA I0	1		
18	90.300.07.003	0	KOLÍK VALCOVÝ KALENÝ / CYLINDRICAL PIN TEMPERED / ZYLINDERSTIFT GEHÄRTET	KOLÍK I6X80	1		
19	90.350.07.002	0	TALÍROVÁ PRUŽINA / DISC SPRING / TELLERFEDER	35.5X18.3X2.0X2.8	8		
20	94.001.005	0	RUKOJET / HANDLE / GRIF	M16	1		
21	95.001.019	0	LOŽISKO / BEARING / LAGER	6206 2RS	2		
22	95.801.010	0	KROUZEK POJIST.VNITR / INSIDE SAFETY RING / SICHERUNGSRING INNEN	POJISTNY KROUZEK 62	1		

Poz. - Position/Position; Císlo vykresu/Drawing number/Zeichnungsnummer

### 7.9. Vedení pásu / Sägebandführung / Belt guide

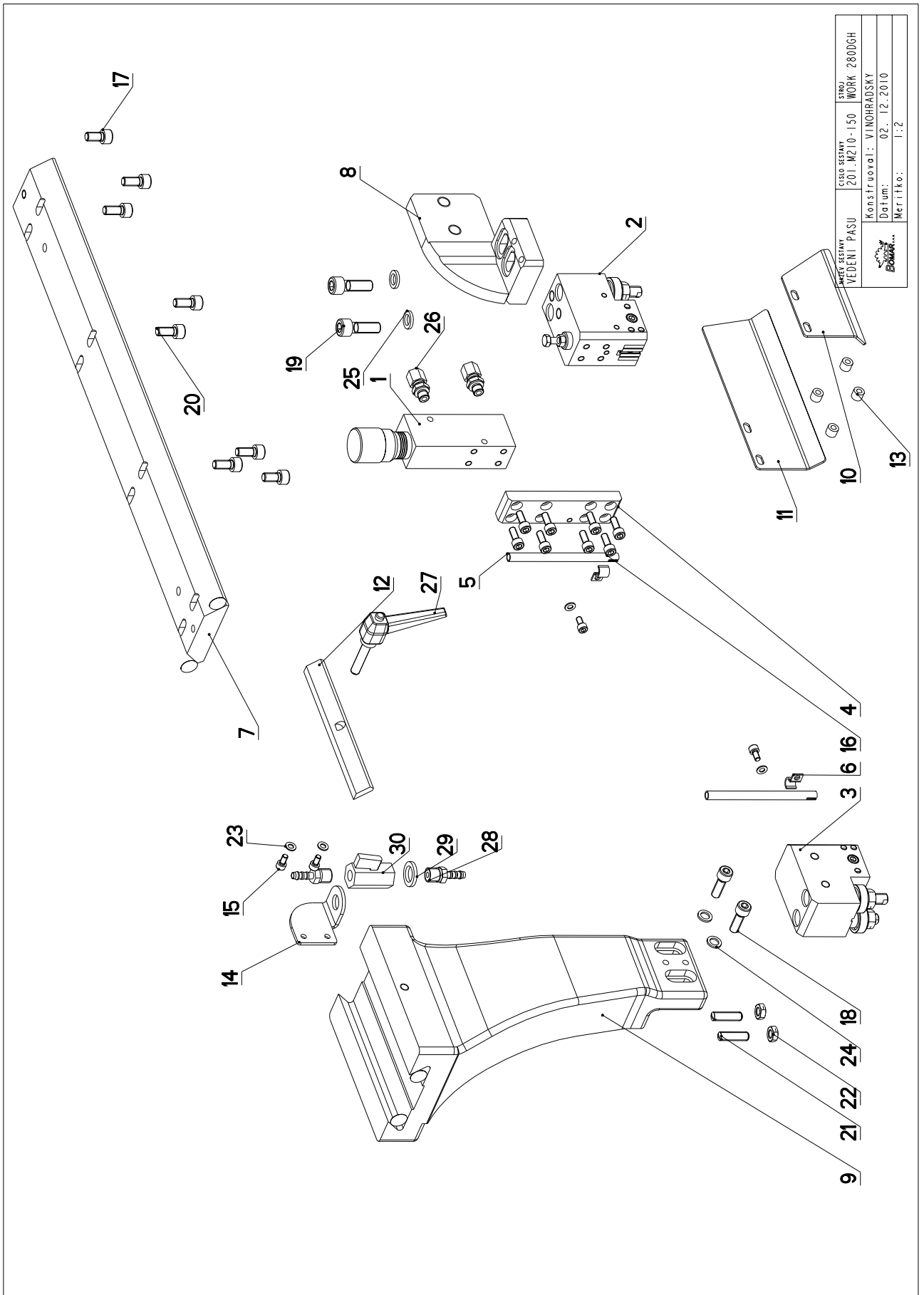

STROJ	WORK 280DGH
CÍSLO RESTAVY	201.MZ10-150
Konstruktor:	VINOHRADSKÝ
Datum:	02. 12. 2010
Verzičko:	1:2





## 7.10. Kusovník / Stückliste / Piece list – Vedení pásu / Sägebandführung / Belt guide

Císlo Sestavy 201.M210-150		Ver. 0		Název sestavy VEDENÍ PASU/BELT GUIDE / SÄGEBANDFÜHRUNG	
Poz.	Objednávací číslo	Ver.	Název položky	Rozměr	Ks
1	251.077	0	REGULACE PRITLAKU / PRESSURE REGULATION / SCHNITTDRUCKREGULATION		1
2	201.M210-110	0	KOSTKA VODICI / LEAD CUBE / FÜHRUNGSKLOTZ		1
3	201.M210-200	0	KOSTKA VODICI / LEAD CUBE / FÜHRUNGSKLOTZ		1
4	30.3510-003	0	DESKA / BOARD / PLATTE	HR 30x12	1
5	30.3510-004	0	TRUBKA / TUBE / ROHR	TR 8x 1	2
6	30.9010-003	0	DRŽAK / HOLDER / HALTER	PI. 5x10	2
7	30.M210-002	0	LISTA / TRIM / LEISTE	HR 80x20	1
8	30.M210-003	0	KONZOLA / CONSOLE / KONSOLE		1
9	30.M210-004	0	KONZOLA / CONSOLE / KONSOLE		1
10	30.M210-006	0	KRYT PASU / BELT COVER / BANDABDECKUNG	P 2x70	1
11	30.M210-007	0	KRYT PASU / BELT COVER / BANDABDECKUNG	P 2x70	1
12	30.M210-008	0	LISTA / TRIM / LEISTE	HR 25x6	1
13	30.Y310-007	0	KROUZEK / RING / RING	TR 10x2,5	4
14	30.Y310-008	0	DRŽAK / HOLDER / HALTER	P.3-50	1
15	90.001.25.007	0	SROUB IMBUS ČERNÝ / ALLEN HEAD BOLT / IMBUSSCHRAUBE	M5X10	4
16	90.001.25.017	0	SROUB IMBUS ČERNÝ / ALLEN HEAD BOLT / IMBUSSCHRAUBE	M6X16	8
17	90.001.25.031	0	SROUB IMBUS ČERNÝ / ALLEN HEAD BOLT / IMBUSSCHRAUBE	8x16	2
18	90.001.25.033	0	SROUB IMBUS ČERNÝ / ALLEN HEAD BOLT / IMBUSSCHRAUBE	8x25	2
19	90.001.25.048	0	SROUB IMBUS / ALLEN HEAD BOLT / IMBUSSCHRAUBE	M10X30	2
20	90.001.25.105	0	SROUB IMBUS / ALLEN HEAD BOLT / IMBUSSCHRAUBE	M8X18	6
21	90.002.20.022	0	SROUB STAVECI / ADJUSTMENT BOLT / STELLSCHRAUBE	SROUB M8X30	2
22	90.101.55.001	0	MATICE / NUT / MUTTER	MATICE M8	2
23	90.150.50.003	0	PODLOZKA / WASHER / UNTERLEGSCHIEBE	PODLOZKA 5,3	4
24	90.163.00.002	0	PODLOZKA / WASHER / UNTERLEGSCHIEBE	PODLOZKA 8	2
25	90.163.00.004	0	PODLOZKA / WASHER / UNTERLEGSCHIEBE	NORD-LOCK	2
26	92.002.102	0	SROUBENÍ / BOLTING / VERSCHRAUBUNG	S-GEV-8LLR	2
27	94.008.003	0	PAKA UPÍNACÍ / ATTACHMENT LEVER / SPANNHEBEL	M6x40	1
28	94.202.002	0	REDUKCE / REDUCTION / ADAPTOR / REDUKTION	REDUKCE 6/R1/4"	2
29	96.081.001	0	KROUZEK TESNICÍ / SEAL RING / DICHTUNGSRING	23x15x3	1
30	99.260.003	0	VENTIL / VALVE / VENTIL	1/4"	1

Poz. - Position/Position; Císlo vykresu/Drawing number/Zeichnungsnummer

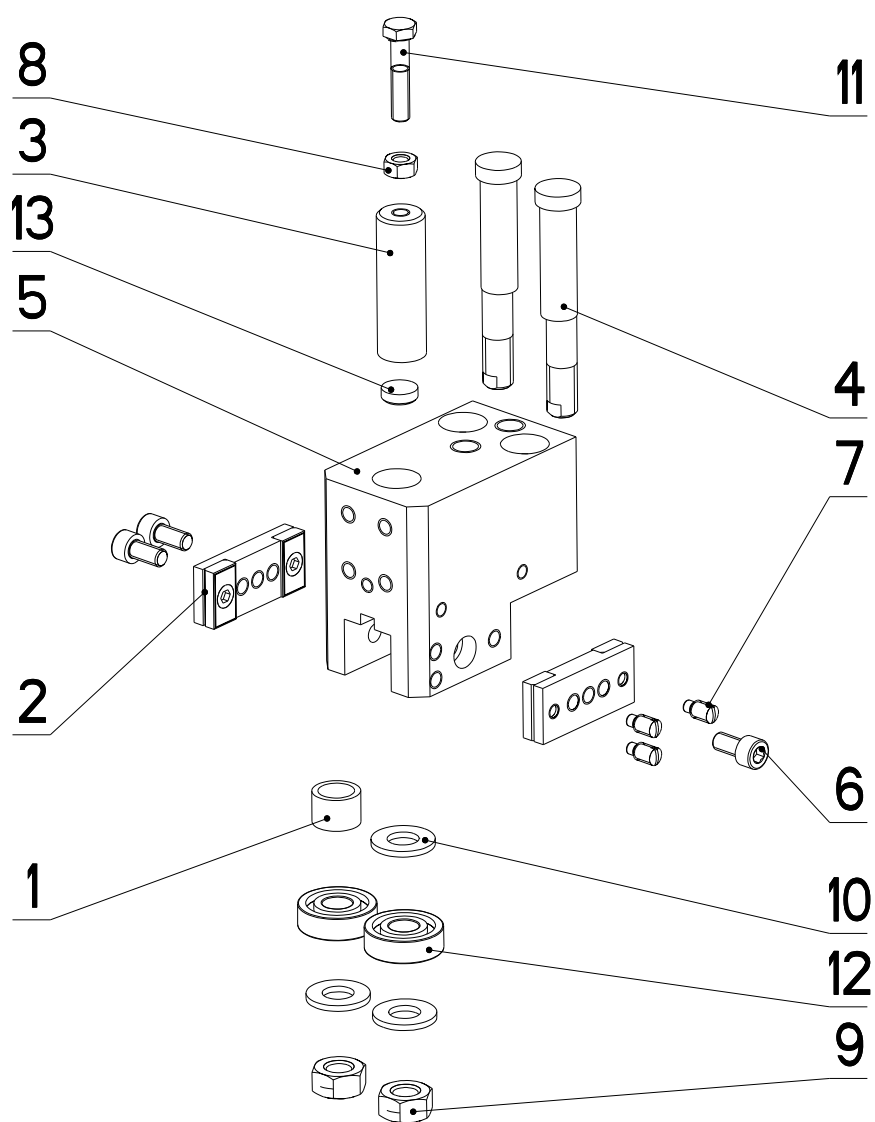
## 7.11. Vodící kostka / Führungsklotz / Guiding cube - 1





NAZEV SESTAVY KOSTKA VODICI	CISLO SESTAVY 201.M210-110	STROJ work280H
	Konstruoval: VINOHRADSKY	
	Datum: 02. 12.2010	
	Meritko: 1:2	

## 7.12. Kusovník / Stückliste / Piece list – Vodící kostka / Führungsklotz / Guiding cube - 1

Císlo Sestavy 201.M210-110		Ver. 0		Název sestavy KOSTKA VODÍCI / LEAD CUBE / FÜHRUNGSKLOTZ	
Poz.	Objednací číslo	Ver.	Název položky	Rozměr	Ks
1	30.1710.006	0	KROUZEK DISTANČNÍ / DISTANCE RING / DISTANZRING	TR 16x2	1
2	30.1710-015	0	DESKA / BOARD / PLATTE		2
3	30.3510-002	1	DRŽÁK TVRDOKOVU / POA HOLDER / HM-HALTER	TYC 16	1
4	30.M210-102	0	EXCENTR / CAM / EXZENTER	∅ 15	2
5	30.M210-111	0	KOSTKA VODÍCI / LEAD CUBE / FÜHRUNGSKLOTZ	TYC 80x50	1
6	90.001.25.016	0	ŠROUB IMBUS / ALLEN HEAD BOLT / IMBUSSCHRAUBE	M6x12	3
7	90.004.2D.002	0	ŠROUB STAVEČI / ADJUSTMENT BOLT / STELLSCHRAUBE	ŠROUB M6x12	3
8	90.100.55.004	0	MATICE / NUT / MUTTER	MATICE - M6	1
9	90.100.55.006	0	MATICE / NUT / MUTTER	MATICE - M10	2
10	90.150.50.006	0	PODLOŽKA / WASHER / UNTERLEGSCHIEBE	PODLOŽKA 10,5	3
11	90.401.0Z.002	0	ŠROUB 6HRANNÝ / 6 SIDED BOLT / SECHSKANTSCHRAUBE	ŠROUB M6x30	1
12	95.001.004	0	LOŽISKO / BEARING / LAGER	6000 2RS	2
13	99.040.002	0	TVRDOKOV / HARD METAL / HM-SEGMENT	∅ 12	1

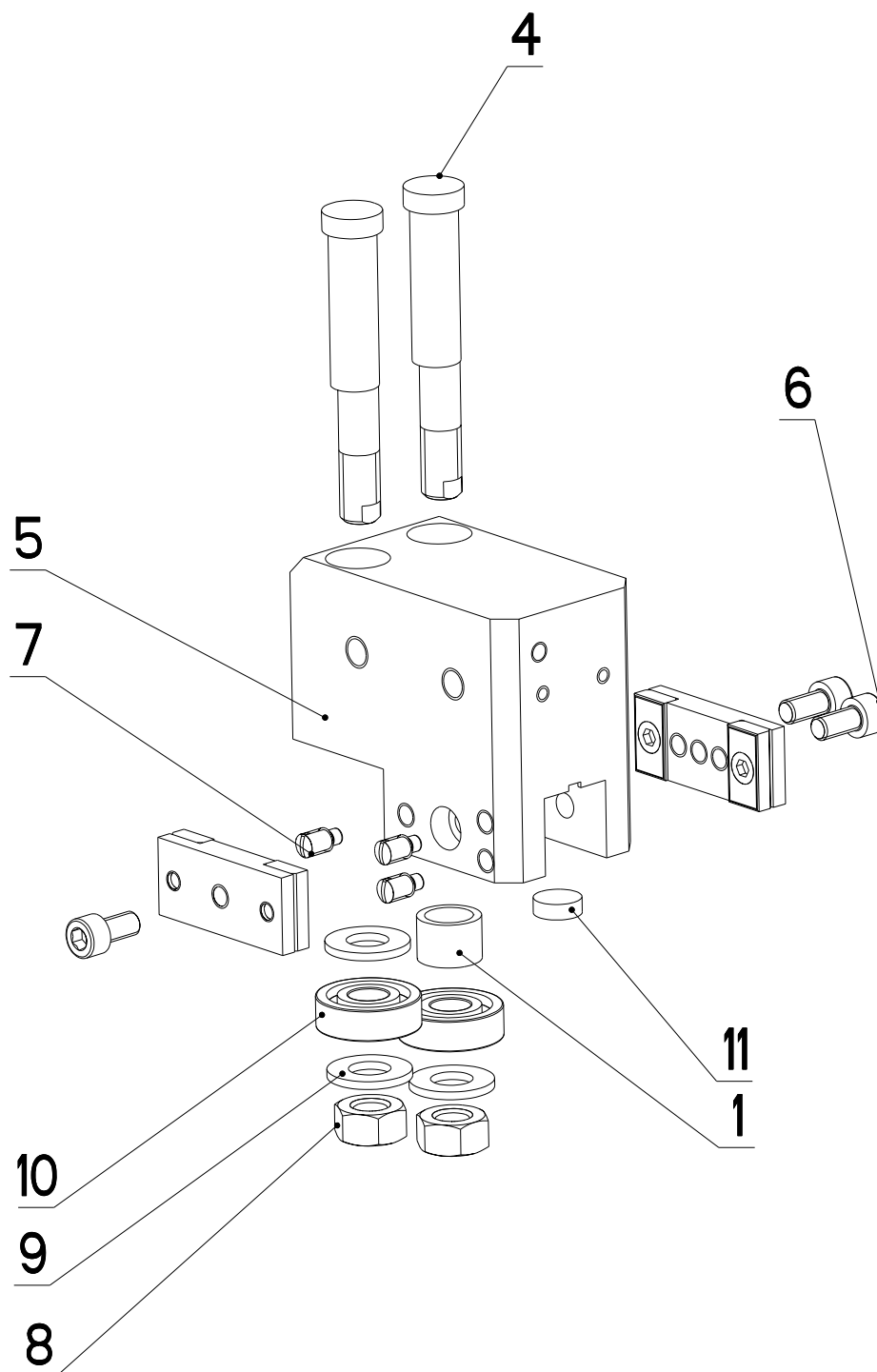
### 7.13. Vodící kostka / Führungsklotz / Guiding cube - 2



NAZEV SESTAVY KOSTKA VODICI	CISLO SESTAVY 201.M210-200	STROJ WORK280
	Konstruoval: &konstruoval	
	Datum: 18. 10.2010	
	Meritko: 7:10	

## 7.14. Kusovník / Stückliste / Piece list – Vodící kostka / Führungsklotz / Guiding cube - 2

Cislo Sestavy 201.M210-200		Ver. 0		Nazev sestavy KOSTKA VODICI / &NAZEV_EN / &NAZEV_DE	
Poz.	Objednací číslo	Ver.	Nazev položky	Rozmer	Ks
1	30.1710.006	0	KROUZEK DISTANČNI / DISTANCE RING / DISTANZRING	TR 16x2	1
2	30.1710-010	0	DESKA / BOARD / PLATTE		1
3	30.1710-015	0	DESKA / BOARD / PLATTE		1
4	30.M210-102	0	EXCENTR / CAM / EXZENTER	ø 15	2
5	30.M210-201	0	KOSTKA VODICI / LEAD CUBE / FÜHRUNGSKLOTZ	HR 80x50	1
6	90.001.25.016	0	SROUB IMBUS / ALLEN HEAD BOLT / IMBUSSCHRAUBE	M6x12	3
7	90.004.20.002	0	SROUB STAVECI / ADJUSTMENT BOLT / STELLSCHRAUBE	SROUB M6x12	3
8	90.100.55.006	0	MATICE / NUT / MUTTER	MATICE _ M10	2
9	90.150.50.006	0	PODLOZKA / WASHER / UNTERLEGSCHLEIBE	PODLOZKA 10,5	3
10	95.001.004	0	LOZISKO / BEARING / LAGER	6000 2RS	2
11	99.040.002	0	TVRDOKOV / HARD METAL / HM-SEGMENT	12x4	1

Poz. - Position/Position; Cislo vykresu/Drawing number/Zeichnungsnummer

## 7.15. Pohon / Antrieb / Drive

Cislo Sestavy 201.M205-000		Ver. 0		Nazev sestavy PREVODOVKA / TRANSMISSION / GETRIEBE	
Poz.	Objednaci cislo	Ver.	Nazev polozky	Rozmer	Ks
1	30.1704-005	3	KOLO HNACI / DRIVE WHEEL / ANTRIEBSRAD	ODLITEK d 45	1
2	30.1704-008	0	PODLOZKA / WASHER / UNTERLEGSCHIEBE	#12x12	2
3	30.1704-012	0	PERO / SPRING / FEDER		1
4	30.3404-060	0	VENTILATOR / VENTILATOR / VENTILATOR		1
5	30.4904-004	0	KROUZEK DISTANCNI / DISTANCE RING / DISTANZRING	TR 55x8	1
6	30.M205-003	0	HRIDEL / SHAFT / WELLE	d 45	1
7	30.M205-004	0	PERO / SPRING / FEDER	HR 10x8	1
8	30.M205-005	0	PRIIRUBA / FLANGE / FLANSCH	ODLITEK	1
9	90.005.55.017	0	SROUB 6HRANNY / 6 SIDED BOLT / SECHSKANTSCHRAUBE	SROUB M8X30	8
10	90.005.55.035	0	SROUB 6HRANNY / 6 SIDED BOLT / SECHSKANTSCHRAUBE	SROUB M12X45	8
11	90.011.27.008	0	SROUB ZAPUSTNY / COUNTERSINK BOLT / SENKTSCHRAUBE	SROUB M10X20	2
12	90.150.50.005	0	PODLOZKA / WASHER / UNTERLEGSCHIEBE	PODLOZKA 8.4	8
13	91.001.044	0	ELEKTROMOTOR / /	TM90-4X B14, 2.2kW	1
14	95.001.021	0	LOZISKO / BEARING / LAGER	6208 ZRS	1
15	95.200.001	0	LOZISKO / BEARING / LAGER	VALECKOVA L. IRADA	1
16	99.001.128	0	PREVODOVKA SNEKOVA / WORM GEAR TRANSMISSION / SCHNECKENGETRIEBE	MU75PAM90B14	1

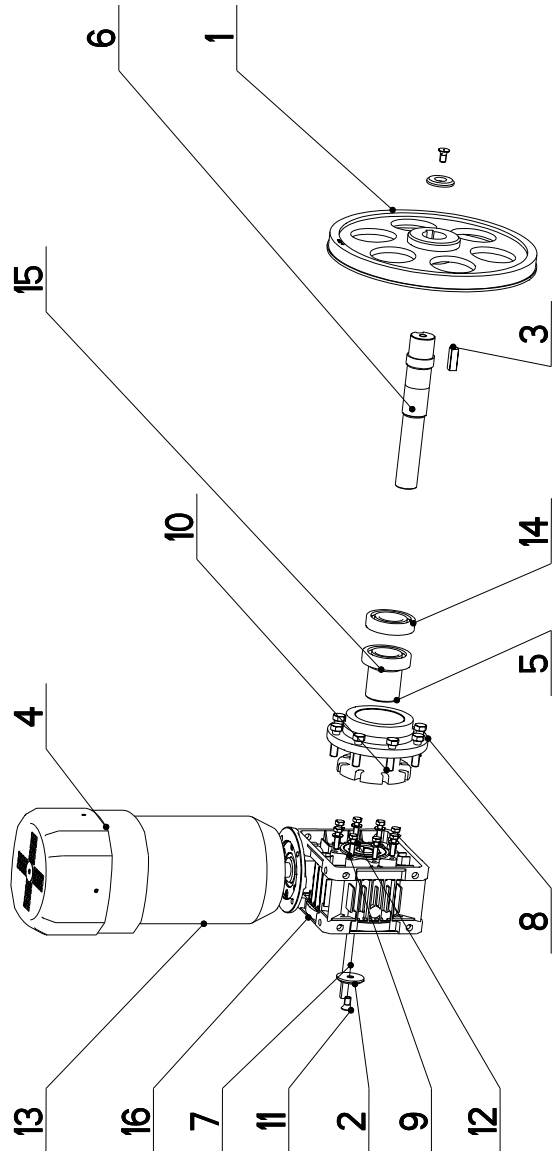

Cislo Sestavy/Number of assembly/Nummer der Baugruppe; Verze (Ver./Version/Version; Nazev sestavy/Assembly title/Name der Baugruppe; Pozice (Poz./Position/Position;  
Objednaci cislo/Purchase order number/Bestellnummer; Nazev polozky/Volume title/Name der Position; Rozmer/Stock size/Abmessung



## 7.16. Podstavec / Untersatz / Base

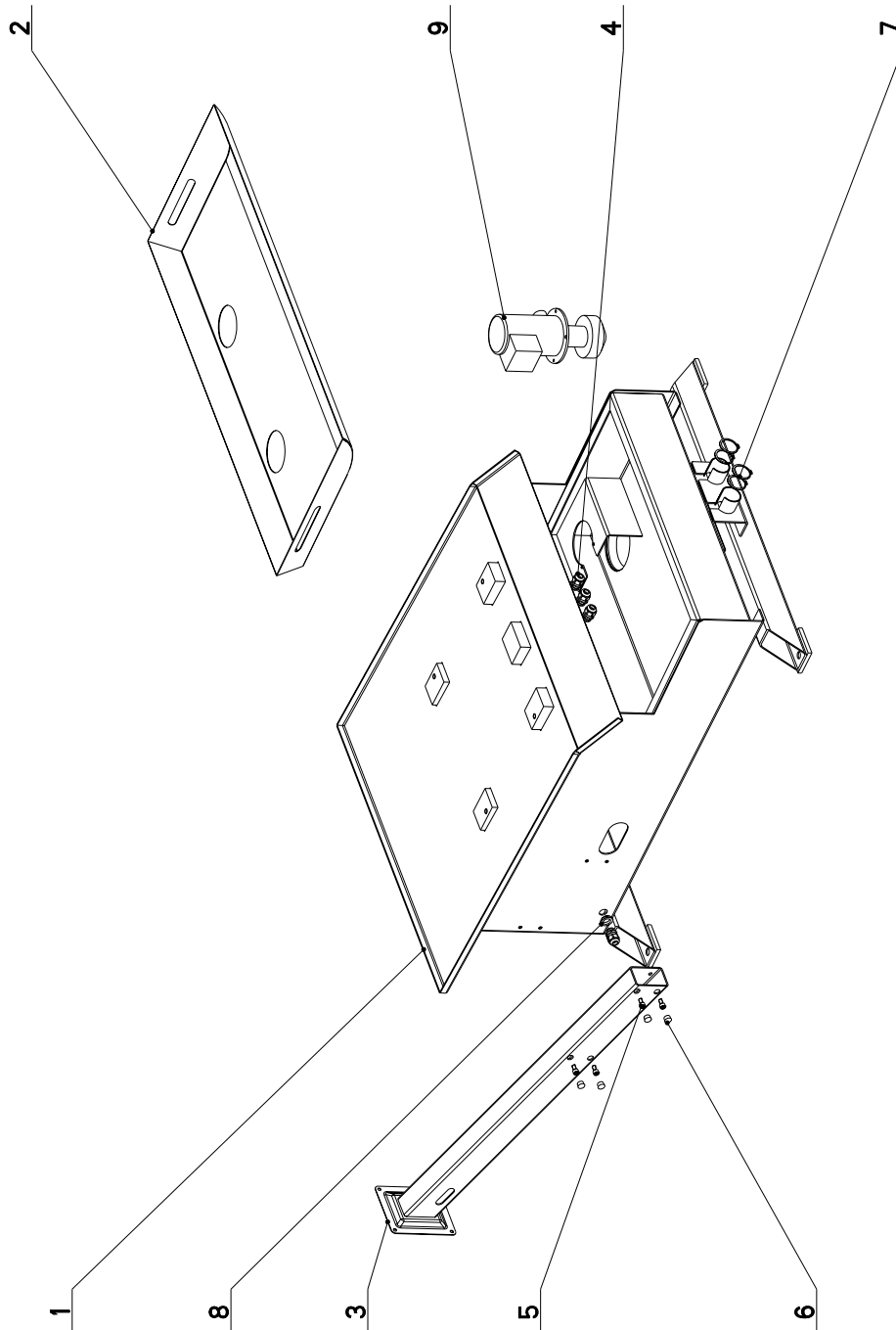

NAZEV SESTAVY PODSTAVEC	CISLO SESTAVY 201.M201-000	STROJ WL 280
		
Konstruoval: VINOHRADSKY		
Datum: 14. 10. 2010		
Meritko: 1:10		



## 7.17. Kusovník / Stückliste / Piece list – Podstavec / Untersatz / Base

Císlo Sestavy 201.M201-000		Ver. 0		Název sestavy PODSTAVEC / &NAZEV_EN / &NAZEV_DE	
Poz.	Objednávací číslo	Ver.	Název položky	Rozměr	K's
1	30.M201-001	0	PODSTAVEC / /		1
2	30.M201-010	0	VANA / TANK / WANNE		1
3	30.M201-004	0	KONZOLA / CONSOLE / KONSOLE		1
4	91.070.012	0	VYVODKA / BUSHING / TÜLLE	M20x1.5	4
5	90.001.25.031	0	SROUB IMBUS CERNENY / ALLEN HEAD BOLT / IMBUSSCHRAUBE	8x16	4
6	94.101.041	0	ZATKA / PLUG / STOPFEN	17x15x9_CERNA	4
7	95.800.016	0	KROUZEK POJIST.VNEJS / OUTSIDE SAFETY RING / SICHERUNGSRING AUBEN	POJISTNY KROUZEK 42	4
8	91.072.012	0	MATICE M 20x1.5 / /		1
9	91.020.015	0	CERPADLO / PUMP / PUMPE	3C0A4-12	1

Císlo Sestavy/Number of assembly/Nummer der Baugruppe; Verze (Ver.)/Version/Version; Název sestavy/Assembly title/Name der Baugruppe; Pozice (Poz.)/Position/Position;  
Objednávací číslo/Purchase order number/Bestellnummer; Název položky/Volume title/Name der Position; Rozměr/Stock size/Abmessung

### 7.18. Ovladací panel / Bedienpult / Control panel

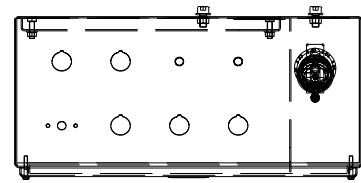
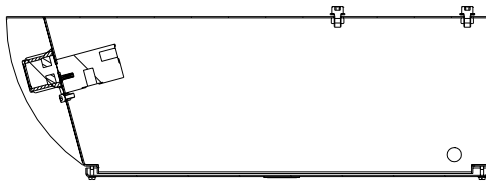
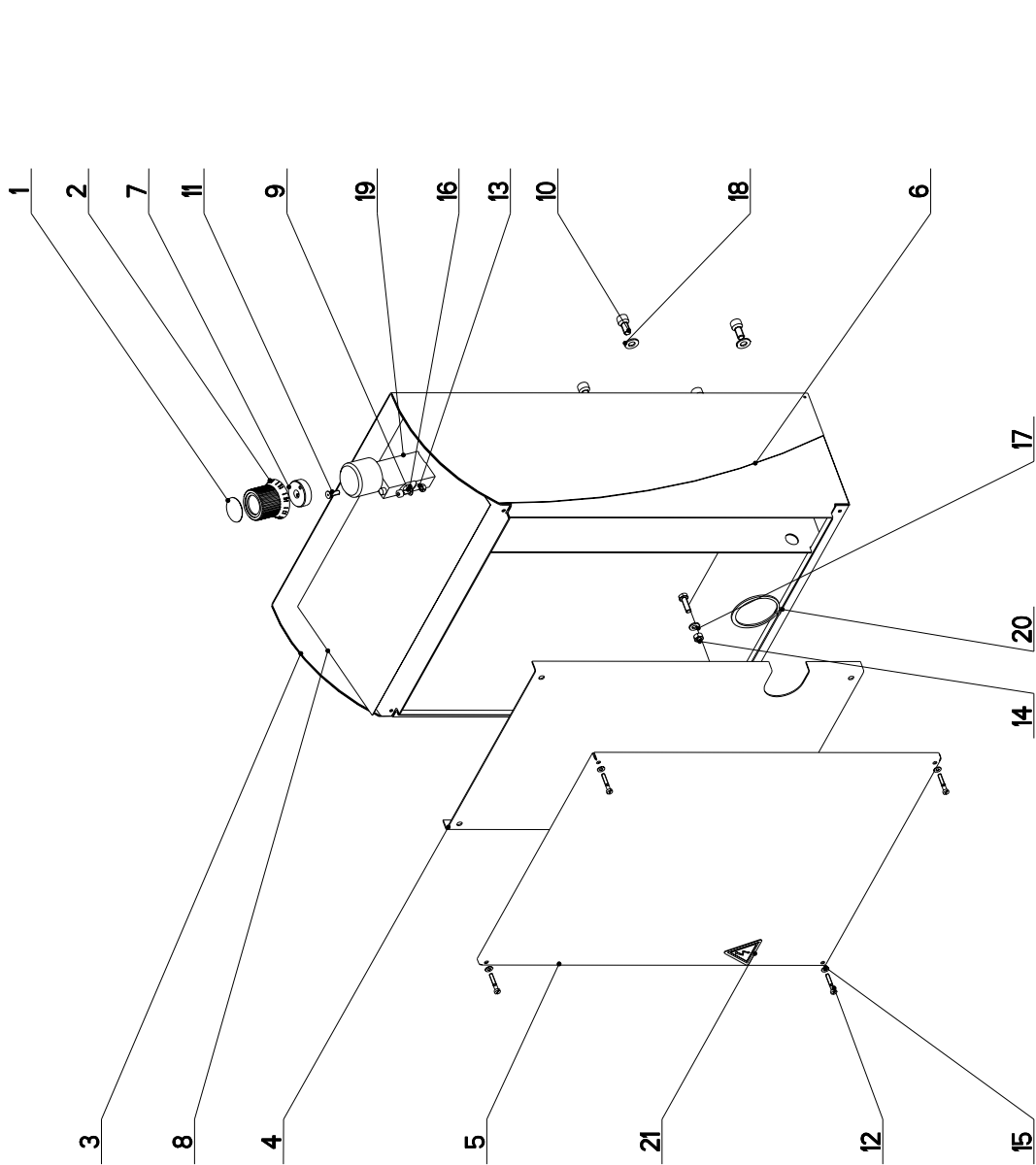

NAZEV SESTAVY OVLADACÍ PANEĽ	CÍSLO SESTAVY 201.M230-100	STROJ WORKLINE
Konstruoval: ODVARKA		
Datum: 03. 03.2011		
Meritko: 1:5		

## 7.19. Kusovník / Stückliste / Piece list – Ovladačí panel / Bedienpult / Control panel

Císlo Sestavy 201.M230-100		Název sestavy OVLADACÍ PANEL/CONTROL PANEL/BEDIENPULT		Ver. 0	Ks
Poz.	Objednací číslo	Ver.	Název položky	Rozměr	Ks
1	30.6130-012	0	VÍKO / COVER / DECKEL	P 0.5x 30x30	1
2	30.6130-018	0	HLAVICE / HEAD / KOPF	VYLISEK	1
3	30.M230-001	0	SKRIN / BOX / KASTEN		1
4	30.M230-002	0	PANEL / PANEL / PANEL	P 1.5x325	1
5	30.M230-003	0	VÍKO / COVER / DECKEL	P 1.5x405	1
6	30.M230-004	1	PLECH / PLATE / BLECH	P 1x170	2
7	30.M230-006	0	MEZIKUS / INTERMEDIATE PIECE / PASSTÜCK	d 32	1
8	31.M230-005	0	SAMOLEPKA / STICKER / AUFKLEBER		1
9	90.001.25.008	0	SROUB IMBUS CERNÝ / ALLEN HEAD BOLT / IMBUSSCHRAUBE	M5X12	1
10	90.001.25.031	0	SROUB IMBUS CERNÝ / ALLEN HEAD BOLT / IMBUSSCHRAUBE	8x16	4
11	90.011.27.022	0	SROUB ZAPUSTNÝ / COUNTERSINK BOLT / SENKSCHEIBE	SROUB M5X16	1
12	90.012.50.006	0	SROUB / BOLT / SCHRAUBE	SROUB M4X25	4
13	90.100.55.003	0	MATICE / NUT / MUTTER	MATICE - M5	1
14	90.100.55.004	0	MATICE / NUT / MUTTER	MATICE - M6	4
15	90.150.50.002	0	PODLOŽKA / WASHER / UNTERLEGSCHIEBE	PODLOŽKA 4,3	4
16	90.150.50.003	0	PODLOŽKA / WASHER / UNTERLEGSCHIEBE	PODLOŽKA 5,3	1
17	90.150.50.004	0	PODLOŽKA / WASHER / UNTERLEGSCHIEBE	PODLOŽKA 6,4	4
18	90.150.50.005	0	PODLOŽKA / WASHER / UNTERLEGSCHIEBE	PODLOŽKA 8,4	4
19	92.152.004	0	VENTIL SKRTICI / CHOKE VALVE / DROSSELVENTIL	VS01-04/R 2.5-0	1
20	95.800.034	0	KROUZEK POJIST.VNEJS / OUTSIDE SAFETY RING / SICHERUNGSRING AUBEN	POJISTINY KROUZEK 55	1
21	99.900.045	0	SAMOLEPKA / STICKER / AUFKLEBER		1

Císlo Sestavy/Number of assembly/Nummer der Baugruppe; Verze (Ver.)/Version/Version; Název sestavy/Assembly title/Name der Baugruppe; Pozice (Poz.)/Position/Position;  
Objednací číslo/Purchase order number/Bestellnummer; Název položky/Volume title/Name der Position; Rozměr/Stock size/Abmessung

## 7.20. Doraz / Anschlag / Stop piece

Cislo Sestavy 201.M209-030		Nazev sestavy DORAZ/STOP PIECE/ANSCHLAG			
Poz.	Objednací číslo	Ver.	Nazev položky	Rozmer	Ks
1	30.M209-031	0	PAKA / LEVER / HEBEL	P 8x60	1
2	95.001.004	0	LOZISKO / BEARING / LAGER	6000 ZRS	1
3	90.001.25.048	0	SROUB IMBUS / ALLEN HEAD BOLT / IMBUSSCHRAUBE	M10X30	1
4	30.M209-032	0	CEP / LUG / BOLZEN	d 20	1
5	90.150.50.005	0	PODLOZKA / WASHER / UNTERLEGSCHIEBE	PODLOZKA 8,4	1
6	90.001.25.039	0	SROUB IMBUS / ALLEN HEAD BOLT / IMBUSSCHRAUBE	M8X55	1
7	31.0206-005	0	PRUZINA / SPRING / FEDER	2.50x16x90x27	1
8	90.163.00.011	0	PODLOZKA / WASHER / UNTERLEGSCHIEBE	NORD-LOCK	1
9	90.163.00.004	0	PODLOZKA / WASHER / UNTERLEGSCHIEBE	NORD-LOCK	2
10	90.101.55.002	0	MATICE / NUT / MUTTER	MATICE M10	1

